

hand holding tie on shoulder and right hand hanging open; wearing short wig, panther skin over robe; over his head three horizontal lines of small signs, facing to right: (1) *it-f rh nšwt*, (2) *hnty-š*, (3) *Tw-nšwt*.

Back of outer niche on right (north): two vertical lines of inscription, facing in to left: (1) *ir-n n-f hm-f nw r imšh-f hr hm-f*; (2) *šk šw cnh hr rdwy-fy hnty-š pr-č hšw* with the name *Hwfw-cnh* written horizontally beneath both lines; under this inscription is an incised horizontal line; under this main part is a small standing figure of the mother, standing facing in to left, with right hand open on breast and left hand hanging open; lappet wig and tunic; over head three horizontal lines: (1) *mwt-f*, (2) *hnty-š* (3) *Twpw*.

Frame panel on left (south): large figure of Khufuw-ankh, standing facing to right, with staff and wand; short wig, panther skin over short skirt; naked boy standing between man and staff with left hand on staff and right hanging; labelled *s-f Mn-kšw-rc-cnh*: above his head four vertical lines ending in two horizontal lines: (1) *dī nšwt htp Inpw dī hnty šh ntr krs m hr-ntr*, (2) *hnty š pr č, hšw, imy-rš hšw pr č*, (3) *imy-rš sbšw, mry nb-f, mrr nb-f*, (4) *idd iht nbt nfrt n nb-f rc nb, imšhw hr nb-f, rh nšwt*, (5) *šhmh ib n nb-f rc nb*, (6) *rh nšwt Hwfw-cnh*.

Frame panel on right (north): large standing figure of wife; facing in to left; right hand open on breast and left hand hanging open; lappet wig, long tunic, necklace; in front of her smaller figure of daughter in same attitude and attire, labelled vertically over head *šn-qt Iti*; behind the woman stands a small naked girl with finger to her mouth, and small pig-tail; labelled *sst-f Mrt-it-š*. Above the woman's head four vertical lines and one horizontal; (1) *dī nšwt htp Inpw dī hnty šh ntr krs m hr-ntr*, (2) *m smyt imnt-t šwt nfrt wrt hr ntr nbt imšh*, (3) *hm ntr Ht-hr nbt nht, hm ntr Nt wpt wšwt mštt inbw*, (4) *prt-hrw n-š m Dhwtyt m wšg*, (5) *rht nšwt Dfšt-kš*.

Decoration of small stela (niche) in west wall of room (b): no tablet or architrave; framed simple stela with top and sides of frame: under top of frame, inner niche with drum and the two backs of the outer niche.

Top of frame, or crossbar, with horizontal line of incised signs, facing to right, *dī nšwt htp Inpw krs m hr-ntr*.

Drum: uninscribed.

Back of outer niche on left (south); nearly obliterated; inscription above *hmt-f Tw(?)pw*.

Back of outer niche on right (north); nearly obliterated; inscription above *hnty-š Tw-nšwt*.

Outer frame panel on left (south); obliterated.

Outer frame panel on right (north); vertical line, *hnty-š n pr-č, hšw(?) Hwfw-cnh*.

Offering-stone: found in place in front of great stela; a large slab of white limestone containing in its upper surface a rectangular basin on the left end, in the middle two circular bowl-like depressions and on the right a circular disk in relief; inscribed across the top end of the basin, *imšhw hr ntr č*; around the raised disk on the right runs a circular band of inscription, *rh nšwt, hšw, hnty-š pr č Hwfw-cnh; hmt-f mrt-f Dfšt-kš*. Stone measures 44 × 25 cm. and about 20 cm. high. Pl. 66 b.

Offering-basin found in place in front of small niche in room (b); simple rectangular offering-basin; inscribed on upper ledge down right side and across top, *imšhw hr ntr, hšw, hnty-š Hwfw-cnh*.

Serdab: in the west wall between the great stela and the small stela a slot window opens into a small serdab, 0.23 × 0.35 m. and 0.56 m. high; slot opening, 3 cm. high and 5 cm. wide; remains of decayed wooden statuette.

Shaft G 4520 A: sole shaft, north of middle, 2.15 × 2.05 m.; lined with massive masonry, 3.75 m.; 7 courses; in the SW corner a smaller rock-cut shaft, 1.47 × 1.47 m.; — 3.9 m. in rock; at 3.9 m. is a ledge and the shaft descends contracted to 1.03 × 1.1 m. to a total depth of 6.2 m. in rock; 3 chambers.

Chamber (1): at 1.15 m. in rock; type 6 d; on east; 1.0 × 0.1 m. and 0.8 m. high; area 0.10 sq. m.; capacity, 0.08 cu. m.; found completely cleared out.

Chamber (2): at 3.9 m. in rock; type 4 b (1); on south; 3.1 × 1.5 m. and 1.6 m. high; area, 4.65 sq. m.; capacity, 7.44 cu. m.

Passage: 0.57 × 0.8 m. and 1.24 m. high; found completely cleared out.

Chamber (3): at 6.2 m. in rock; type 5 a (1); on west; 2.7 × 2.3 m. and 1.4 m. high; area, 6.21 sq. m.; capacity, 8.69 cu. m.

Passage: 0.35 × 1.05 m. and 1.2 m. high.

Blocking: partly in and partly out of doorway; rough masonry with sloping face on shaft side mud plastered; type IV c (2); probably intact.

Coffin: wooden *krst* coffin with inner lining of sides and ends of wood; *krst*-coffin, outside, 2.1 × 0.8 m. and c. 0.6 m. high (height of lid, 18–24 cm.); inner case, inside, 1.72 × 0.43 m.; thickness of outer case, 8 cm.; thickness of lining, 6 cm.; thickness of floor-boards, 8 cm. See Fig. 309.

Burial: in inner case, a half contracted skeleton (turned over on back) wrapped in linen (limbs separately); linen badly decayed; under head, alabaster head-rest.

Many objects on floor of chamber; see below.

Pl. 66 e (blocking), Pl. 66 f (objects on floor), Pl. 67 a (coffin), Pl. 67 b (body in coffin).

Objects: found in debris in shaft:

14-3-63: copper; model chisel; length, 9.0 cm.; w. 0.9 cm. Pl. 69 e (2/2), Fig. 310.

Objects: found in chamber (3):

14-4-12: alab.; head-rest, one piece, with fluted stem; h. 20.9 cm.; length of base, 18.4 cm.; length of top, 17.1 cm.

Pl. 69 d (found in coffin), Fig. 310.

Alabaster Model Vessels:

Type S-I d: alab.; jar, models; 6 examples:

14-4-3: h. 4.3–4.4 cm.; d. 2.8–3.0 cm. (a) h. 4.2 cm.; d. rim, 2.8 cm.; d. min., 2 cm.; d. base, 2.4 cm. Pl. 68 f (2/3), Fig. 310.

Type S-XIV b: one-handled jug, dummy model; 1 example:

14-4-2: alab.; h. 4.9 cm.; d. top, 2.0 cm.; d. body, 3.6 cm.; d. base, 1.8 cm.; unpierced handle. Pl. 68 f (1/1), Fig. 310.

Type S-XV a: shoulder-jar; 2 examples:

14-4-5: alab.; h. 6.3 cm.; d. neck, 2.0 cm.; d. shoulder, 3.4 cm.; d. base, 2.0 cm. Pl. 68 f (1/3), Fig. 310.

14-4-6: alab.; h. 7.2 cm.; d. neck, 2.8 cm.; d. shoulder 4.8 cm.; d. base, 2.2 cm. Pl. 68 f (2/1), Fig. 310.

Type S-XVI b: collar jar with ring-stand in one piece; 2 examples:

14-4-1: alab.; h. 7.6 cm.; h. ring-stand, 2 cm.; d. top, 2 cm.; d. collar, 2.2 cm.; d. body, 3.4 cm.; d. ring-stand, top, 2.2 cm.; d. base, 2.0 cm.; (b) h. 8.3 cm.; d. 3.6 cm. Pl. 68 f (2/2), Fig. 310.

Type S-X b: model basin with convex sides; 5 examples:

14-4-4: alab.; h. 1.7–2.0 cm.; d. max. 4.8–6.6 cm.; (a) h. 2.2 cm.; d. top, 4.2 cm.; d. max. 4.8 cm.; d. base, 3.0 cm. Pl. 68 f (1/2), Fig. 310.

Sum total of alab. models: 11 jars (4 types) and 5 basins (one type); total, 16 models.

Pottery found in chamber:

Group A: round-bottomed and pointed jars:

Type A-II b: large wine-jar; 2 examples:

14-4-21: WSR, yellow slip; with remains of mud stoppers; h. 33.6 cm.; d. rim, 8.8 cm.; d. neck, 8.2 cm.; d. body, 19.0 cm. Pl. 69 b (1/1), Fig. 310.

14-4-22: WSR, yellowish slip; incomplete; h. 34.4 cm.; d. rim, 10 cm.; d. neck, 8 cm.; d. max. 19.2 cm. Pl. 69 b (1/2).

Group B: flat-bottomed jars:

Type B-LV b-m: models of neckless shoulder-jar; 9 examples:

14-4-15: RBrW; 6 examples; with splay foot; h. 4.5–5.6 cm.; d. 5.1–6.6 cm.; (a) h. 5.4 cm.; d. rim, 3.6 cm.; d. max. 5.8 cm.; d. min. 2.8 cm.; d. base, 3.6 cm. Pl. 69 c (2/2), Fig. 310.

14-4-19: RW, red wash; 3 examples; with splay foot; h. 7.5–8.1 cm.; d. 8.5–8.9 cm.; (a) h. 8.2 cm.; d. rim, 5.2 cm.; d. max. 9.0 cm.; d. min. 4.3 cm.; d. base, 4.2 cm. Pl. 69 c (2/1), Fig. 310.

Type B-LVI a-m: model collar jar with splay foot; 3 examples:

14-4-16: BrW; h. 8.4–8.6 cm.; d. max. 4.3–4.6 cm.; (a) h. 8.3 cm.; d. top, 3.8 cm.; d. collar, 4.0 cm.; d. max. 4.4 cm.; d. min. 3.2 cm.; d. base, 4.0 cm. Pl. 69 c (1/1), Fig. 310.

Type B-LVIII: degenerate model of belted barrel jar with splay foot: 1 example:

14-4-17: BrW; h. 7.4 cm.; d. rim, 4.2 cm.; d. max. 4.6 cm.; d. min. 3.0 cm.; d. base, 4.0 cm. Pl. 69 c (2/3), Fig. 310.

Type B-LIX b: practical jug with tall neck, bulging shoulder, with nearly upright tubular spout, tapering body with narrow flat base; 1 example:

14-4-13: RBrW, red wash; h. 34.3 cm.; d. rim, 12.4 cm.; d. neck at base, 8.0 cm.; d. body, 16 cm.; d. base, 3.2 cm.; w. with spout, 18.6 cm. Pl. 69 a, Fig. 310.

Group C: round-bottomed basins and bowls: no examples.

Group D: flat-bottomed basins and bowls:

Type D-XXXV c: model of basin with contracted mouth and open spout: 1 example:

14-4-18: BrW; h. 4.0 cm.; d. rim. 7.0 cm.; d. max. 7.6 cm.; d. base, 5.0 cm.; w. with spout, 8.4 cm. Pl. 69 c (1/2), Fig. 310.

Type D-LXXIX a: model basin with straight sides and splay foot; 94 examples:

14-4-14: BrW; 94 examples; about 2.0 m. high with diameter of c. 6.5 cm.; (a) h. 1.9 cm.; d. max. 6.4 cm.; d. base, 4.0 cm. Pl. 69 c (1/3), Fig. 310.

SUMMARY OF POTTERY:

Group A: type II b, 2; total 2 jars.

Group B: type LV, 9; LVI, 3; LVIII, 1; LIX, 1; total 14 jars.

Group C: no examples.

Group D: type XXXV c, 1; LXXIX, 94 small models; total 95 small models.

Sum total: jars, 16 examples (3 practical jars and 13 models); basins, 95 (all models); sum total of vessels, 111 examples of which 3 were practical vessels and 108 models; total of types 7.

Copper: models of tools; 5 different tools.

14-4-7: copper; knife with tang; in frags.; length, 12.9 cm.; w. 1.7 cm. Pl. 69 e (1/1), Fig. 310.

14-4-8: copper; model adze; length, 6.8 cm.; w. edge, 1.4 cm.; w. butt, 1.2 cm. Pl. 69 e (3/2), Fig. 310.

14-4-9: copper; model adze, incomplete; length, 7.4 cm.; w. edge, 1.1 cm. Pl. 69 e (4/2), Fig. 310.

14-4-10: copper; model chisel; length 8.3 cm.; w. max. 0.9 cm. Pl. 69 e (5/2), Fig. 310.

14-4-11: copper; model axe-head; with one and probably three tie holes along flat side (handle side); length, 4.9 cm.; h. of flat side, 5.4 cm. Pl. 69 e (2/1), Fig. 310.

Mud sealing: found in chamber:

14-4-20: mud (sealing clay); box sealing with string mark; 4.8 × 3.6 cm. and 3.2 cm. high; impressed with cyl. seal with 6 vertical lines of which only the Horus name in a frame was legible, *Hr Ir-mꜣrt* (= *Wsr-kꜣf*).

Later Constructions:

Against the east face of the core north of the chapel was a composite mastaba, the result of repeated additions and alterations: this covered the face of the core from the north end of the exterior chapel of G 4520 to the NE corner of the core and westwards along the north end for a distance of 4.8 m.; these constructions were numbered as they appeared, G 4522 north of the NE corner and along the face of the core, and G 4523 on south against the chapel; in G 4522 was a corridor chapel of type (5 c) with deep recess at south end and a serdab behind the south wall; in the debris around this complex were found a number of frags. of statuettes, 14-3-20, 21, 23-25, 27-32, 62 (see Pl. 67 e); farther away NE of G 4520 was found:

14-3-4: num. lst.; seated man and wife with naked boy between them; h. 43.5 cm.; w. 27.0 cm.; inscribed on left side of seat a horizontal and four vertical lines of inscription: *rḥ nꜣwt Hwfw-ꜥnh*, (1) *ir-n n-f nw sꜣ-f . . .*, (2) *hnt . . .*, (3) *m st . . .*, (4) *hr nb-f . . . sn m . . .*; on basis in front of boy, *sꜣ-f mry-f Mn-kꜣw-rꜥ-ꜥnh*; on front of throne, beside legs of both man and woman, unintelligible inscriptions. Pl. 67 c.

14-3-16, 23, 32: num. lst.; standing pair man and wife; h. 43 cm.; inscribed on back of support, *iry ṣḏꜣwt n pr-ꜥ, hnty ṣ Kꜣp*: woman labelled, *hmt-f mrt-f Hy*. Pl. 67 d.

14-3-24, 31: w. lst.; incomplete seated pair, man and wife; small size; man labelled, *rḥ nꜣwt hnty-ṣ n pr-ꜥ imꜣhw hr ntr ꜥ Kꜣp*: woman labelled, *hmt-f imꜣh (t) N-ꜥnh-Hthr*. Photos. C 5731, 5729.

14-3-21: lst. frag. of crossbar or architrave; l. 25 cm., h. 13.5 cm. and 6.5 cm. thick; incised, *ir ꜥnt N-ṣꜣṣꜣ-nꜣwt* (identical with the *N-ṣꜣṣꜣ-nꜣwt* of statuette in chapel of G 4410, and the *hm-kꜣ* priest on the north jamb of G 4411 (*L.D.* II, 89 c)). Photo. C 5730.

The names on these statuettes indicated that the persons named were all connected with Khufuw-ankh; one statuette with wife and son was undoubtedly made later by a son; the man Kap, represented by two pair

statuettes, is possibly the same as the Kap shown on the great stela as first member of the *sn-dt* of Khufuw ankh.

G 4524: small rubble mastaba built against the north end of G 4520 west of G 4522.

G 4525: small rubble mastaba built against the east face of G 4520 and against the south end of the masonry of room (b).

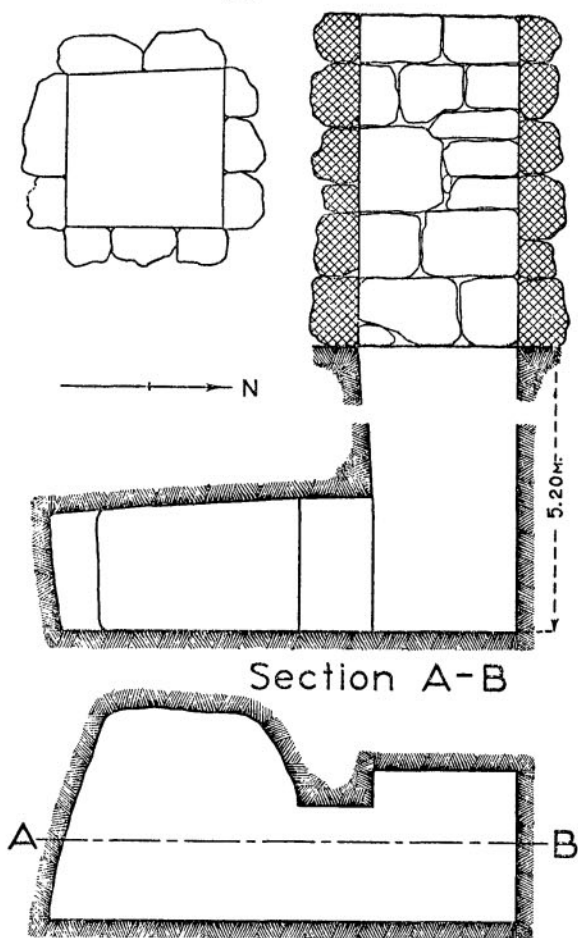

Plan 0 1 2 3M.
Fig. 311. G 4260 A

(d) length, 7.3 cm.; w. max. 1.5 cm.

(e) length, 6.1 cm.; w. max. 1.3 cm.

Pl. 69 f, Fig. 312.

Pottery:

Group A: round-bottomed and pointed jars:

Type A II b: large wine-jar; frags. of 1 jar.

14-3-68 d: WSR (pinkish); 4 frags.

Group B: flat-bottomed jars:

Type B-LI b: bag-shaped jar with flat bottom; 1 example:

14-3-65: RBrW, wet smoothed; h. 8.6 cm.; d. rim, 7.8 cm.; d. max., 9.5 cm.; d. base, 4.8 cm. Pl. 69 g (1/2), Fig. 312.

Type B-LIV: two-handled oil-jars; 1 example:

14-3-67: special ware, cream slip; incomplete; h. 23.2 cm.; d. rim, 7.0 cm.; d. neck, 5.2 cm.; d. body, 16 cm.; d. base, 8.4 cm.; w. with handles, 20 cm. Pl. 69 h, Fig. 312.

Group C: round-bottomed basins and bowls:

Type C-XXXII: with recurved rim and round bottom; it is probable that 14-3-68 a included one or more RP bowls of type C-XXXII.

All these small mastabas appear to have belonged to persons related to Khufuw-ankh or his funerary service.

G 4620: row 2, line 6.

See Map 6 and Figs. 311 (shaft), 312 (objects).

See Pls. 67 f, 68 a and b, 69 f-h; 70 a.

Excavated: February 27th-28th, March 11th-14th; streets: March 15th to April 25th, 1914.

Owner: Ka-nofer, *ss r n swt* (incised in large signs on east face of core).

Mastaba: core type IV-i, not cased; 22.85 × 9.85 m.; area, 225.07 sq. m.; prop. 1/2.32; h. 4.05 m.; 3 courses.

Chapel: exterior rubble chapel of type (1 d); one N-S offering-room with face of core as west wall; 7.2 × 1.5 m.; area, 10.8 sq. m.; prop. 1/4.8; no niche in west wall; entered from east at north end of east wall.

Shaft G 4620 A: sole shaft; 2.05 × 2.1 m.; -5.20 m. in rock; lined above with massive masonry, 4.35 m.; 5 courses.

Chamber: type 4 b (1) irregular; on south; 3.0 × 2.75 m. and 1.75 m. high; area, 8.25 sq. m.; capacity, 14.43 cu. m.; lower part of shaft and walls of chamber mended with small pieces of stone and plaster.

Passage: 1.0 × 1.5 m. and 1.8 m. high.

Blocking: interior blocking of type II c (2), penetrated.

Completely plundered except for potsherds and flint flakes.

14-3-19: flint; 5 flint flakes and two frags.; pointed end with rounded butt and rhomboidal section in middle:

(a) length, 9.6 cm.; w. max. 1.0 cm.

(b) length, 8.1 cm.; w. max. 1.1 cm.

(c) length, 8.6 cm.; w. max. 1.1 cm.

Group D: flat-bottomed basins and bowls:

Type D-XXXVI: recurved rim with spout; probably included in frags.

14-3-68a: RP; frags. of recurved rims.

Type D-XXXIX b: flaring bowl with concave sides, and plain rim; 1 example:

14-3-66: RP; incomplete; h. 20.4 cm.; d. rim, 27.2 cm.; d. base, 12.0 cm. Pl. 69 g (1/1), Fig. 312.

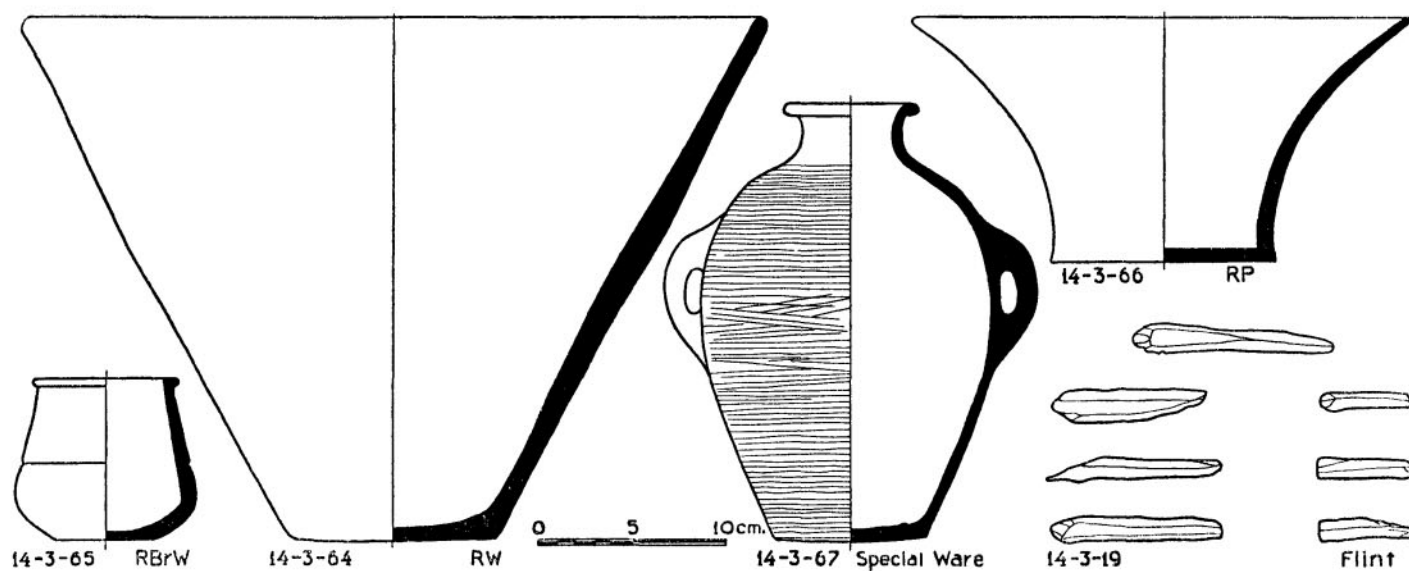

Fig. 312. G 4620 A

Type D-LXXIII: straight spreading sides with plain rim: 1 example:

14-3-64: RW, red wash; incomplete; h. 27.8 cm.; d. top, 39.3 cm.; d. base, 11.0 cm. Photo. C 5753, Fig. 312.

Type D-LXXV: flaring bowl with internal moulding; frags.; 1 example.

14-3-68 c: RBrW, wet smoothed; frags.

Unidentified:

14-3-68 b: thick ware with black fracture, RP; frag. from rim of a large basin with moulded rim.

SUMMARY OF POTTERY:

Group A: type II b, 1; total 1 example.

Group B: type LI, 1; LIV, 1; total 2 examples.

Group C: type XXXII (?), 1 or more.

Group D: type XXXIX, 1; LXXIII, 1; LXXV, 1; XXXVI (?), 1; total 4 or more.

Sum total: 8 or more in 8 types.

Later Constructions: only one full partly destroyed mastaba was built against the east face of the core, G 4622; two shafts were found, G 4623 north of NE corner of core and G 4624 south of the chapel against the SE corner.

G 4621: three-shaft E-W mastaba built against the south end of G 4630 abutting on the west wall of the court.

Alabaster statuettes of 'Prince' Khnum-ba-f (G 5230) were broken up in the street east of G 4620 after it had been covered with a light layer of drift sand; we found in this sand just above the rock a great number of frags. of alabaster including two heads (14-3-1 and 2) one of which joins with an inscribed panel with the name of 'Prince' Khnum-ba-f found with other fragments SE of G 4830.

G 4720: row 2, line 7.

See Map 6 and Figs. 313 (shaft), 314 (objects).

See Pls. 68 c and d, 70 a-f.

Excavated: February 1st to March 13th, 1914.

Mastaba: core type IV-i, not cased; 23.3 × 9.8 m.; area, 228.34 sq. m.; prop. 1/2.38; h. 5.0 m.; 4 courses.

Chapel: no trace was found; the place where an exterior c.b. chapel would have stood was covered by the south end of G 4722, leaving a passage 2 m. wide along the face of G 4720.

Shaft G 4720 A: sole shaft; 2.2×2.2 m. lined with massive masonry, 5.0 m.: 5 courses; smaller rock-cut shaft in NW corner, 1.6×1.8 m.; -5.0 m. in rock.

Chamber: type 4 b (1) irregular; on south; 2.5×1.7 m. and 1.55 m. high; area, *c.* 4.0 sq. m. (irregular); capacity, 6.2 cu. m.

Passage: 0.5×1.3 m. and 1.4 m. high; irregular step down from floor of passage to floor of chamber, 0.15 m.

Blocking: interior wall of rough masonry set in plaster; type III c (1), partly preserved.

No trace of coffin or skeleton; on floor scattered potsherds and a few ox-bones.

Objects: found in thieves' debris in shaft:

14-3-58: flint: four flakes:

(a) razor with worked rounded ends, l. 9.4 cm.; w. 2.6 cm.; thickness, 0.5 cm. Pl. 70 a (1), Fig. 314.

(b) narrow pointed flake: l. 8.4 cm.; w. 1.2 cm. Pl. 70 a (1/2), Fig. 314.

(c-d) two small frags. like (b): l. 5.5 cm.; w. 1.3 cm. Pl. 70 a (4/2, 3).

Pottery: found in thieves' debris partly in shaft and partly in chamber:

Group A: round-bottomed or pointed jars:

Type A-II b: large wine-jar; frags of rim (2 examples):

14-3-56: hard brown ware, black fracture, wet smoothed; frag.

14-3-57 e: WSR; frag. rim.

Group B: flat-bottomed jars:

Type B-LI b: flat-bottomed bag-shaped jar; 1 example:

14-3-34: BrW; h. 10.0 cm.; d. rim (roll rim), 7.2 cm.; d. max. 11.2 cm.; d. base, 4.2 cm. Pl. 70 b (2/1), Fig. 314.

Type B-LV b: neckless shoulder-jar; 5 examples; one large jar and 4 large models:

14-3-35: BrW; 3 examples; h. 8.1-9.5 cm.; d. max. 9.7-10.1 cm.;

(a) h. 9.8 cm.; d. rim, 6.2 cm.; d. max. 9.8 cm.; d. base, 5.0 cm. Pl. 70 b (2/2), Fig. 314.

14-3-36: RBrW; incomplete; h. 10.7 cm.; d. rim, 7.0 cm.; d. shoulder, 10.7 cm.; d. base, 5.0 cm. Pl. 70 b (1/5).

14-3-45: RP; h. 26.0 cm.; d. rim, 9.0 cm.; d. shoulder, 13.8 cm.; d. base, 10 cm. Pl. 70 c (1/2), Fig. 314.

Type B-LV b-m: small models of neckless shoulder-jar with splay foot; 4 examples:

14-3-39: BrW; 4 examples; h. 4.9-6.2 cm.; d. 5.8-6.3 cm.; (a) h. 6.2 cm.; d. rim, 4.2 cm.; d. shoulder, 6.0 cm.; d. min. 3.2 cm.; d. base, 4.0 cm. Pl. 70 b (1/4), Fig. 314.

Type B-LVI a: collar jar; large models with splay foot; 5 examples:

14-3-37: BrW; h. 9.7 cm.; d. top, 3.6 cm.; d. collar, 4.3 cm.; d. body, 4.6 cm.; d. min., 3.0 cm.; d. base, 3.6 cm. Pl. 70 b (1/1).

14-3-38: BrW; 3 incomplete models of about the same size as 14-3-37.

14-3-41: BrW; 1 example; h. 8.6 cm.; d. top, 3.8 cm.; d. collar, 4.8 cm.; d. body, 5.2 cm.; d. min. 3.0 cm.; d. base, 3.6 cm. Pl. 70 b (1/2), Fig. 314.

Type B-LVIII: barrel jar with belt, splay foot; 2 examples:

14-3-40: BrW; h. 8.1 cm.; d. top, 4.0 cm.; d. max. 5.2 cm.; d. min. 3.0 cm.; d. base, 3.2 cm. Pl. 70 b (1/3), Fig. 314.

Group C: round-bottomed basins and bowls:

Type C-XXXII a: bowl with recurved rim; 2 (?) examples:

14-3-54: WSR, heavy ware; 2 frags. of rim with different curvature; the slope indicates type C-XXXII, but the ware is unusual.

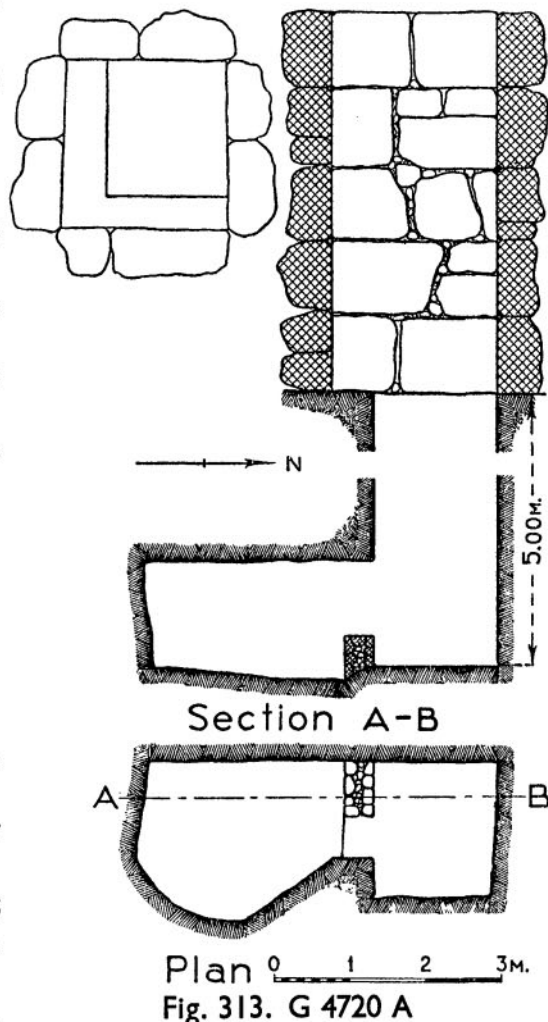

Fig. 313. G 4720 A

Type C-XXXII b: with high recurved rim; 3 examples:

14-3-42: RP; incomplete; h. 8.8 cm.; d. rim, 23.6 cm.; d. body, 23.4 cm. Fig. 314.

14-3-43: RP; incomplete; h. c. 7.5 cm.; d. 20.5 cm.

14-3-44: RP; incomplete; h. 8.0 cm.; d. rim, 20.4 cm.; d. body, 21.6 cm. Fig. 314.

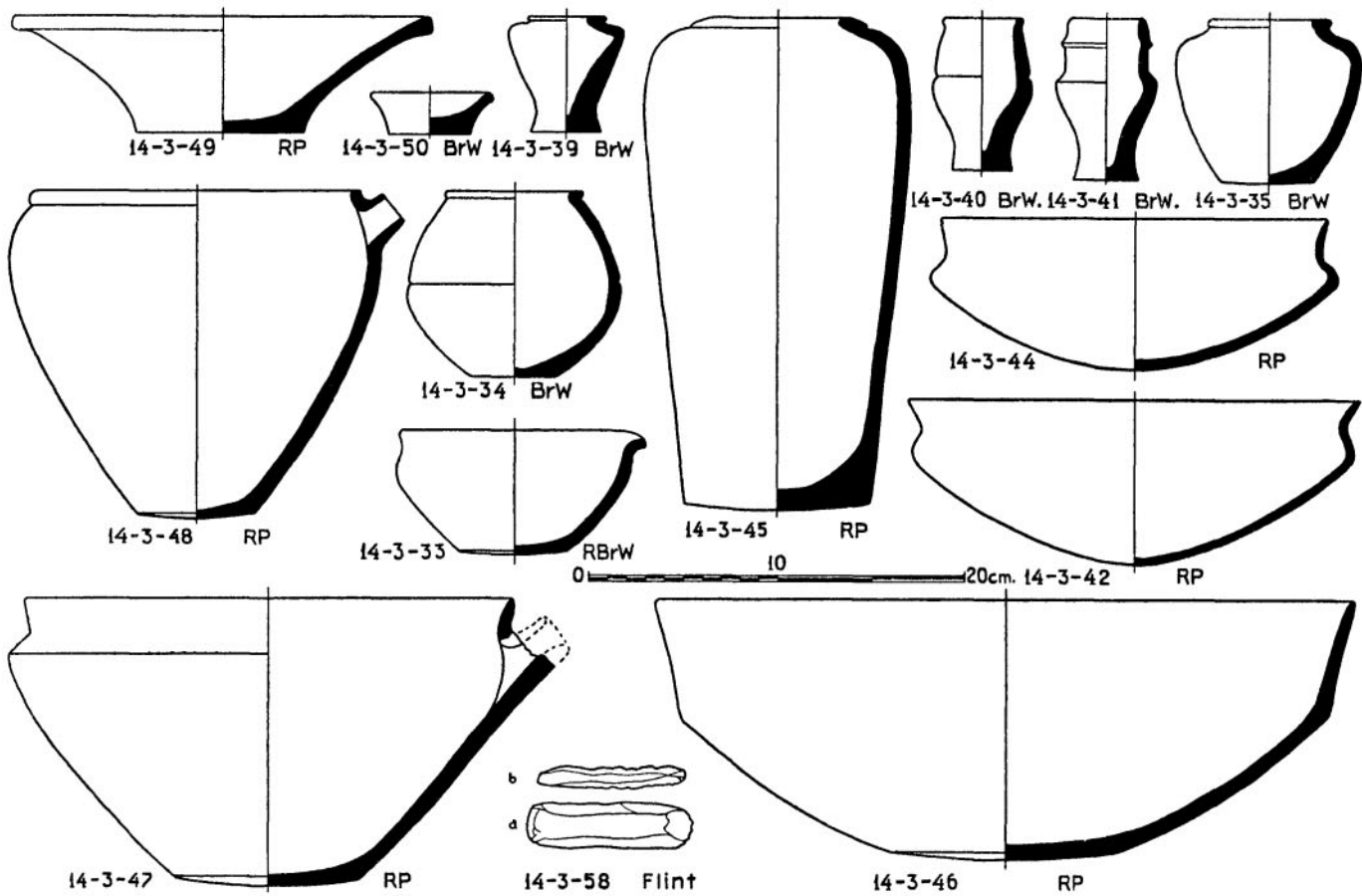

Fig. 314. G 4720

Group D: flat-bottomed basins and bowls:

Type D-XXXV a: basin with short tubular spout; 3 examples:

14-3-48: RP; 2 examples, incomplete; (a) h. 35.2 cm.; d. rim, 35.2 cm.; d. max. 40.0 cm.; d. base, 12.0 cm.; w. with spout, 40.8 cm.; (b) h. 30.6 cm.; d. max. 36.3 cm. Pl. 70 e (1/1-2), Fig. 314.

14-3-55: RW, wet smoothed; frag. of small basin.

Type D-XXXV c: basin with open spout; model; 1 example:

14-3-33: RBrW; h. 6.4 cm.; d. rim, 12.0 cm.; d. max. 12.8 cm.; d. base, 5.0 cm.; w. with spout, 13.0 cm. Pl. 70 b (2/3), Fig. 314.

Type D-XXXVI a: recurved rim and long tubular spout; 3+ examples:

14-3-47: RP; incomplete (end of spout broken off); h. 15.2 cm.; d. rim, 25.2 cm.; d. body, 27.2 cm.; d. base, 9.6 cm.; w. with spout, 29.6+ cm. Pl. 70 d, Fig. 314.

14-3-53: RP; many frags. of recurved rims like the type; one or more examples.

14-3-57 h: RP; frag. with tubular spout. Pl. 70 c (1/1).

Type D-XXXIX a: flaring bowl with concave sides; frags. of 1:

14-3-51: RP; 2 frags.

Type D-XXXIX c: flaring bowl with straight sides and moulded rim; 1 example:

14-3-49: RP; incomplete; h. c. 6.3 cm.; d. rim, 22.4 cm. Fig. 314.

Type D-LXXV: flaring bowl with internal moulding; 3 examples:

14-3-57 a, b, f: coarse RW; frags. of three different vessels; (a) h. c. 5.0 cm.

Type D-LXXXVI b: bent-sided bowl with plain rim; 2 examples:

14-3-46: RP; incomplete; h. 13.8 cm.; d. rim, 36.6 cm.; d. bend-line, 34.0 cm.; d. base (slightly convex), 12.0 cm.
Pl. 70 f, Fig. 314.

14-3-52: RP; frags.; h. c. 20 cm.; d. c. 36 cm.

Type D-LXXXIX a: model basins with straight sides; 38+ examples:

14-3-50: BrW; 38+ examples; h. 1.7-2.5 cm.; d. 5.7-7.2 cm.; (a) h. 2.2 cm.; d. max. 6.4 cm.; d. base, 4.2 cm.
Pl. 70 b (1/6), Fig. 314.

Frag. of vessels of unidentified type; 3 examples:

14-3-57 c: thick brown ware; frag. of a rim of basin (?).

14-3-57 d: BrW; frag. from rim of small bowl.

14-3-57 g: RBrW, wet smoothed; rim of basin with moulded rim.

SUMMARY OF POTTERY:

Group A: type II b, 2; total 2 examples.

Group B: type LI, 1; LV, 5; LV b-m, 4; LVI, 5; LVIII, 2; total 17 examples.

Group C: type XXXII, 5; total 5 examples.

Group D: type XXXV, 4; XXXVI, 3+; XXXIX, 2; LXXV, 3; LXXVI, 2; LXXIX, 38+; total 52+ basins of which 38+ were small models.

Unidentified vessels, 3 vessels.

Sum total of vessels, 79+; 76+ of identified types and 3 unidentified.

Total types identified, 13 types.

Later Constructions:

G 4721: built against the south end of G 4730 in avenue north of G 4720; medium mastaba of u-masonry with interior chapel of type (7 b); between this and G 4720 were found frags. of granite pair (two men) seated (14-2-15); unscribed; and the top of an alabaster head-rest (14-2-14) probably from plundered shaft of G 4721; in the shaft a sealing of Nefer-f-ra (*Hr Nfr-hrw*) and 4 canopic jars.

G 4722: built in street east of G 4720 against the back of G 4820; leaving a passage between G 4720 and G 4722.

G 4723: a single shaft against the east face of G 4720 near NE corner.

G 4724: a small mastaba built against the north end of G 4722.

G 4725: in street east of north end of G 4720; built against the south end of G 4733: stone mastaba, badly destroyed.

G 4820: row 2, line 8.

See Map 6 and Fig. 315 (shaft).

See Pl. 68 e.

Excavated: Feb. 12-18, Dec. 29, 31, 1914; Jan. 2, 5, 12, 1915.

Mastaba: core type IV-i; not cased; 23.9 × 10.3 m.; area, 246.17 sq. m.; prop. 1/2.32; h. 4.4 m., 4 courses.

Chapel: the street east of G 4820 was covered with a layer of hard packed debris thrown from a shaft (G 4820 A or G 4930); this layer had been levelled off and on it later constructions were built, in particular the mastaba G 4821 at the north end; at the south end of the street opened the doorway (facing north) of G 4813; on excavating this hard debris (January 19th, 1915), a rubble chapel was exposed towards the south end of the core and south of it an unintelligible c.b. wall (E-W).

Exterior one room rubble chapel of type (1 d) south of middle of core:

(a) N-S offering-room, 4.05 × 1.7 m.; area, 6.89 sq. m.; prop. 1/2.38; with face of core exposed in west side; no niche; entered from east by doorway in south end of east wall.

Shaft G 4820 A: sole shaft; 2.05 × 2.05 m.; lined with massive masonry, 4.6 m.; 7-8 courses; rock-cut smaller shaft in SW corner; 1.5 × 1.5 m. at top contracting to 1.0 × 1.1 m.; -3.7 m. in rock; lower part of shaft and chamber irregularly cut in bad rock.

Chamber: type 6 b irregular; on south; c. 2.1 × 1.4 m. and 1.3 m. high; area, c. 2.94 sq. m.; capacity, 3.82 cu. m.
No trace of burial or equipment found.

Later Constructions:

G 4821: built around the NE corner of G 4820, partly against its east face and partly against its north end and extending north to abut on the south end of G 4830 and G 4833.

G 4822: no mastaba preserved but three shafts west of G 4821 and south of G 4830; large quantity of potsherds of good types were found in shaft B but were undoubtedly intrusive.

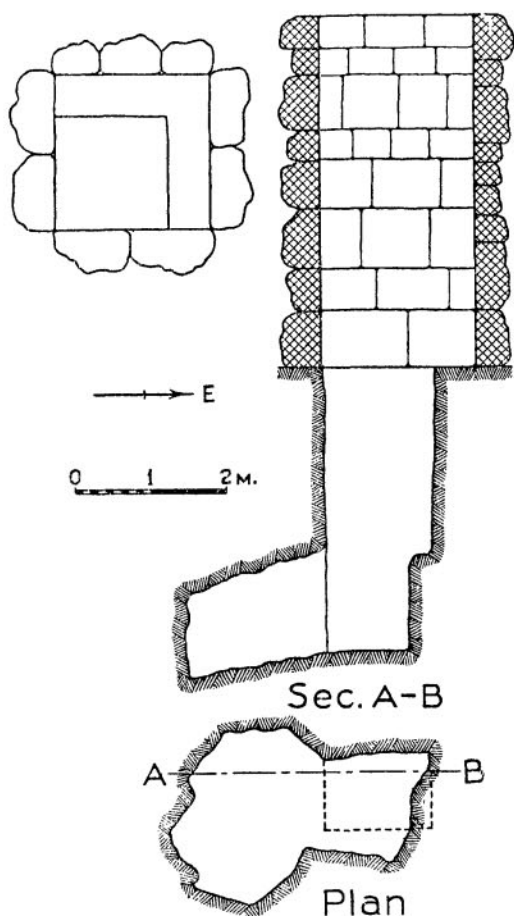

Fig. 315. G 4820 A

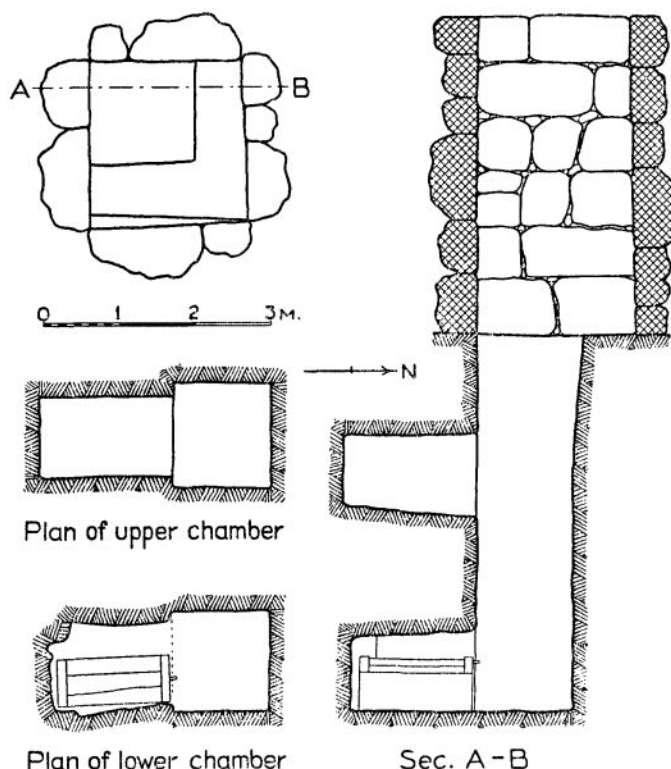

Fig. 316. G 4310 A

6. The last addition of five mastabas: G 4310-4710.

G 4310: row 1, line 3.

See Map 6 and Fig. 316 (shaft).

See Pl. 70 g, 71 a.

Excavated: December 31st, 1915, to January 5th, 1916.

Mastaba: core type IV-i, not cased; 24.0×9.5 m.; area, 228.0 sq. m.; prop. $1/2.52$; h. 4.1 m.; 5-6 courses.

Chapel: probably an exterior c.b. chapel, but no trace remains; one niche is cut in the massive core masonry towards the north end of the east face, at 5.79 m. from the NE corner; a simple niche with drum and architrave, 11 cm. wide and 4 cm. deep; the height is 1.1 m.; not inscribed; against the east face south of the niche stands a small composite mastaba of later date, G 4312, which extended to near the SE corner of the core.

Shaft G 4310 A: sole shaft; 2.05×2.2 m.; lined with masonry above, 4.2 m.; 6 courses; smaller rock-cut shaft in SW corner; 1.4×1.35 m.; -5.0 m. in rock; two chambers.

Chamber (1): at 2.4 m. in rock; type 6 b (1); on south; 1.8×1.05 m. and 1.05 m. high; area, 1.9 sq. m.; capacity, 1.99 cu. m.; found open and empty.

Chamber (2): at 5.0 m. in rock; type 6 b (2); on south; 1.65×1.15 m. and 1.0 m. high; area, 1.89 sq. m.; capacity, 1.89 cu. m.

Blocking: exterior leaning wall set in plaster; blocking type IV b (1).

Coffin: plain wooden coffin with *krst* lid; outside, 1.5 × 0.62 m. and 0.5 m. high; h. of *krst* lid, 0.22 m.

Burial: skeleton, half contracted, head north and face east; wrapping entirely decayed.

No objects found.

G 4410: originally core of type IV-i in row 1, line 4.

See Map 6 and Figs. 317 (shaft), 318 (objects).

See Pl. 71 b-f.

Excavated: December 21st-31st, 1915.

Mastaba: in place of an old core and perhaps reconstructed from its blocks of stone; reconstructed mastaba of

type IX a (1) with retaining walls of large blocks of grey nummulitic limestone (with sloping faces partly dressed); 22.75 × 9.8 m.; area, 220.25 sq. m.; prop. 1/2.33; h. 3.8 m.; sloping batter.

Chapel: exterior chapel of type (8 g) built of u-masonry contains a N-S offering-room with serdab behind its south wall and an exterior c.b. room.

(a) N-S offering-room with one stela at south end of west wall; 5.1 × 1.55 m.; area, 7.91 sq. m.; prop. 1/3.29; entered from east from room (b), by doorway in north end of east wall; in the NW corner was a c.b. compartment containing two small limestone statuettes:

15-12-46: w. lst.; perfect (remains of colour); h. 38.5 cm.; w. 22.5 cm.: inscribed on left side of basis, *imy-rj ššr N-špšš-nšwt* (Ne-shepses-nesuwt); on right side, *hm-kj N-špšš-nšwt*; short wig, ears covered; right hand closed and left open on thighs. Pl. 71 d (*in situ*), Pl. 71 e.

15-12-47: w. lst.; in three pieces, complete; seated man; short wig (not ridged), ears covered; right hand closed and left open on thighs; colour on body; face damaged; on right side, facing to right; *Ṛst-ṛnh*; h. 28.0 cm.; w. 11.5 cm. Pl. 71 d (*in situ*), Pl. 71 f.

15-12-48: pottery bowl found in debris of chamber.

(b) exterior corridor of c.b., built around doorway to (a), filling the angle between room (a) and the serdab; 5.55 × 1.7 m.; area, 9.44 sq. m.; entered from north; doorway to (a) on west.

Total area (a) and (b), 17.35 sq. m.

Subsidiary north niche: cut in mastaba façade, north of chapel.

Serdab: large E-W serdab in masonry south of room but extending eastwards; 1.0 × 4.6 m.; area, 4.6 sq. m.; lined with masonry preserved to a height of about 1 m.; this serdab, found empty, was intended for statuettes of the owner of G 4410; the two small statuettes in the offering room deposited later represent figures of two funerary priests; slot opening in middle of south wall of (a) leads to serdab.

Shaft G 4410 A: sole shaft; 1.7 × 1.6 m.; -11.9 m. in rock; lined above with massive masonry, 3.8 m.; 6 courses.

Chamber: type 4 b (1); on south; 3.55 × 3.0 m. and 1.95 m. high; area, 10.65 sq. m.; capacity, 20.76 cu. m.

Passage: 0.9 × 1.6 m. and 1.95 m. high.

Blocking: interior rough stone set in mud; type II c (2); upper part penetrated by thieves.

Coffin: white limestone coffin with *krst* lid: outside, 2.6 × 1.02 and 0.75 m. high; height of *krst* lid, 0.2 m.; inside, 2.0 × 0.5 and 0.55 m. deep; standing N-S along west wall of chamber; well-dressed surfaces.

Built canopic receptacle: in SE corner, partly destroyed; outside, 0.8 × 1.2 m. and 0.45+ m. high.

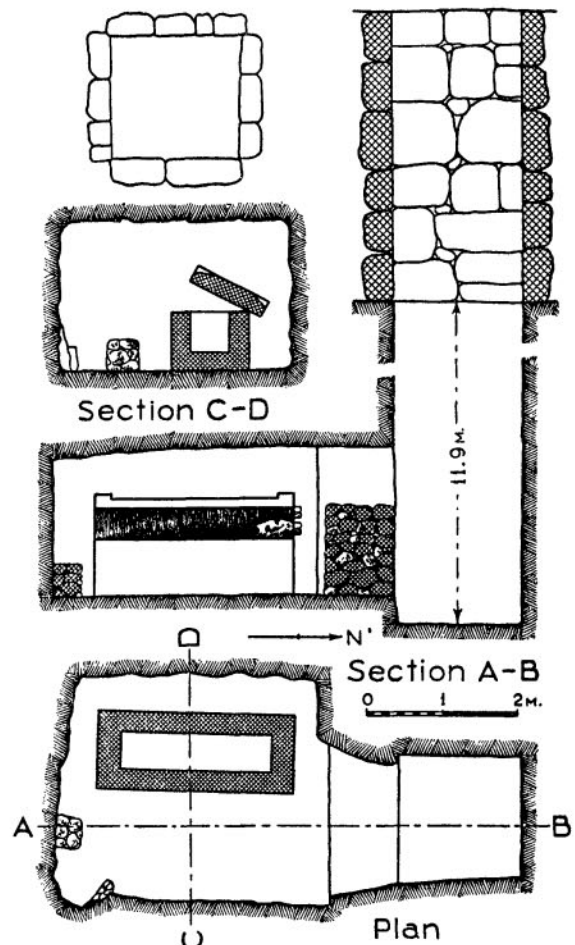

Fig. 317. G 4410 A

Burial: plundered and bones (including skull) scattered.

On the floor in thieves' debris were scattered a leg bone of an ox, copper models, potsherds, &c.

Miscellaneous Objects:

15-12-49: mud (sealing clay); box sealing with imprint of string on flat bottom; 2 frags., about $\frac{2}{5}$ th of seal; impressed with cylinder seal; impressions damaged but clearly legible in two places is a rectangular frame (not a Horus frame) containing the name *Tr-Mst*, the Horus name of Weserkaf; perhaps to be read *Ht-Tr-mst*: dates the burial to Weserkaf or later.

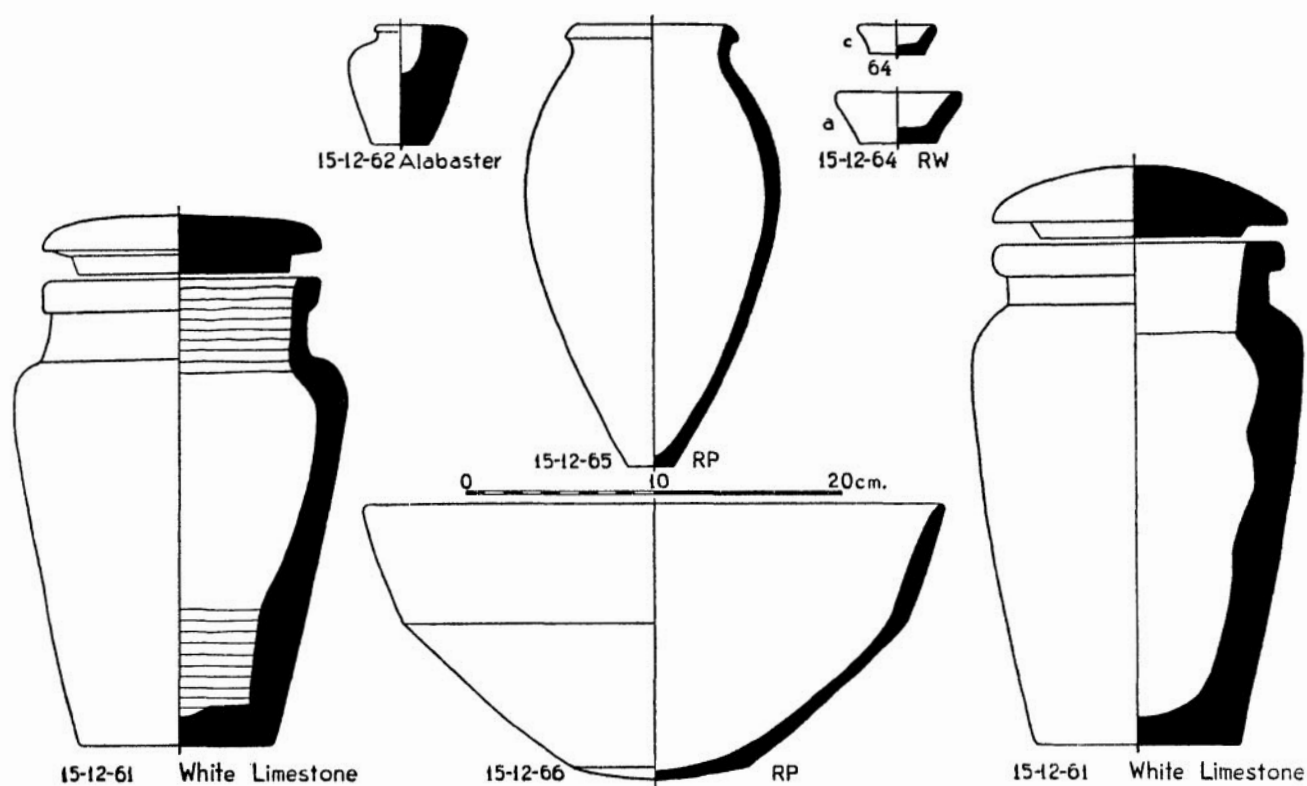

Fig. 318. G 4410

15-12-50: faded faience: beads from necklace:

(a) 39 short cyl. beads; length, 5-13 mm.

(b) 2 ring beads.

(c) one end piece, 2.7 × 3.1 mm.

15-12-51: gold: few frags. of crumbled leaf.

15-12-52 to 58: copper: models, tools, and implements:

(52) adze, in 3 pieces; length about 5.5 cm.

(53-56) 4 drills; length, 4.1-5.5 cm.

(57) model of vessel with spout; frag. length of spout, 3.5 cm.

(58) about 40 frags. of model implements and vessels.

15-12-59: sandstone; upper part of a plummet; h. 4.1 cm.

15-12-60: white plaster, painted yellow; covers of model granary jars; 10 examples; each made of two pieces stuck together; h. 3.7-4.4 cm.; d. 2.2-2.3 cm.

15-12-61: w. lst.; 4 canopic jars with domed lids; h. 24.6-26.4 cm.; d. 17.3-19.4 cm.; (a) h. 24.6 cm.; d. rim, 14.8 cm.; d. max. 17.3 cm.; d. base, 10.6 cm.; (b) h. 26.4 cm.; d. rim, 15.4 cm.; d. max. 17.4 cm.; d. base, 10.8 cm. Photo. B 3982 (2/1-4). Fig. 318.

15-12-62: alab.; model one-handed jug with unpierced handle; type S-XIV b; h. 6.4 cm.; d. rim, 3.6 cm.; d. shoulder, 5.6 cm.; d. base, 2.8 cm.; w. with handle, 5.2 cm. Fig. 318.

15-12-63: two halves of a bivalve shell (one decayed); length, 10.5 cm.; w. 6.5 cm.

POTTERY.

Group B: flat-bottomed jars:

Type B-XVIII a: slender jar with roll rim on mouth and narrow flat base; 1 example:

15-12-65: RP; h. 23.4 cm.; d. rim, 8.8 cm.; d. body, 13.4 cm.; d. base, 2.6 cm. Fig. 318.

Type B-LIV: two-handled oil-jar; special ware; 1 example:

15-12-67: special ware; incomplete; h. 38 cm.; d. rim, 10 cm.; d. neck, 7 cm.; d. body, 20 cm.; d. base, 8.5 cm.; w. with handles, 24 cm.

15-12-69: plaster stopper probably from 15-12-67; with imprint of saucer (upside down) on lower surface; h. 5.0 cm.; d. max. 13.0 cm.

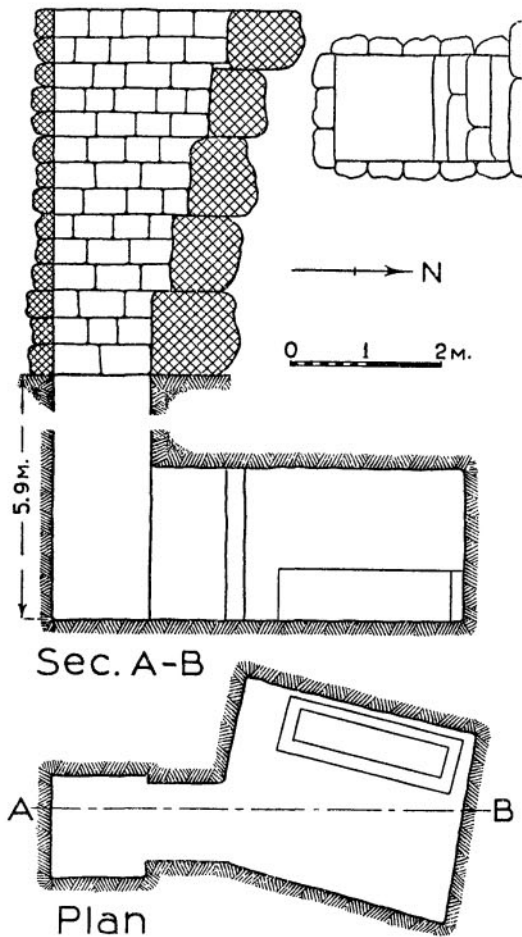

Fig. 319. G 4411 A

Group D: flat-bottomed basins and bowls:

Type D-LXXVI b: bent-sided bowl with flat bottom: 1 example:

15-12-66: RP; h. 14.5 cm.; d. rim, 30.6 cm.; d. bend-line, 26.6 cm.; d. base (slightly convex), 8.4 cm.; h. upper part, 6.3 cm. Fig. 138.

Type D-LXXIX: RW; model basins with straight sides, spreading; 8 examples:

15-12-64: RW; 8 examples, 5 complete; (a) h. 2.7 cm.; d. max. 6.8 cm.; d. base, 4.2 cm.; (b) h. 2.5 cm.; d. max. 6.4 cm.; d. base, 4.6 cm.; (c) h. 1.6 cm.; d. max. 4.3 cm.; d. base, 3.0 cm. Fig. 138.

SUMMARY OF POTTERY:

Group B: type XVIII, 1; LIV, 1; total 2 jars.

Group D: type LXXVI, 1; LXXIX, 8; total 9 examples.

Sum total, 11 vessels, of which 8 were models; total types, 4.

Remains of mummy and meat offerings:

15-12-68: frags. of plaster; white plaster which had been laid over wood in some cases and over cloth in others; probably from mummy and coffin: largest pieces, 3.0 × 2.8 cm.

15-12-81: skull with jaw-bone attached.

15-12-82: upper leg bone of ox.

Later Constructions:

G 4411: built between the north wall of G 4410 and the south wall of G 4420; described below.

G 4412-4416: a secondary cemetery of small mastabas south of G 4410 and south of its exterior chapel.

G 4411 = LG 51: built between G 4410 and G 4420 projecting into street to east.

Excavated: April 19th-25th, 1914.

See Map 6 and Fig. 319. Pl. 72 a.

Owner: Sekhem-ka, *hry-hb*, *hry šst*, *hm ntr Hr Thnw(?) kst-c, wr idt*.

Mastaba: type VIII a; 3.75 × 10.65 m.; area, 39.93 sq. m.; projection: 8.3 × 3.35 m.; area, 27.81 sq. m.; total area, 67.74 sq. m.; E-W mastaba; h. 4.8 cm. of grey nummulitic block.

Chapel: two-room interior chapel:

(a) N-S offering-room of white limestone; with two *ka*-doors in west wall; 2.2 × 1.01 m.; area, 2.22 sq. m.; prop. 1/2.18; relation, 1/17.43; entered from east from (b) at north end of east wall.

(b) vestibule, N-S corridor; 4.6 × 1.45 m.; area, 6.67 sq. m.; entered from east by door in middle of east wall: nummulitic limestone; doorway to (a) in middle of west wall.

Total area (a), (b), 8.89 sq. m.; relation 1/3.11.

Decoration of Chapel: the entrance to room (a) was decorated, architrave, drum, and two door-jambs (now in Berlin Museum): the rest of room (a) was not decorated: room (b) except for the door to (a) was not decorated.

Architrave (Lepsius, *Denkmäler*, Pl. 89 b): two horizontal lines facing to right with seated figure on left end facing to right; left hand on tie of panther skin and right clenched on thigh: (1) *di nswt Inpw htp hnty sh ntr krs-t-f (m) smyt imnt-t isw nfr wrt nb imsh hr ntr* ♂, (2) *pri-hrw n-f wp rnpt Dhwtyt tpy rnpt W:g hb wr rkh prt-Mnw hb nb r n nb hry-hb, hry sst: n*; and vertically in front of figure *hry-hb Shm-k*.

Drum: *hry-hb Shm-k*.

North door-jamb (Lepsius, *Denkmäler*, Pl. 89 c; Steindorff, *Kunst der Ägypter*, Pl. 196): large figure of man standing with staff and wand facing out; full wig, broad necklace, *hry-hb* sash; short skirt with pleated back; chin beard; between man and staff stands naked boy facing to right holding staff with left hand; side-lock and broad collar, labelled, *st-f Mnw-hr(f)*; above beside the drum, five vertical lines: (1) *hry-hb, hry sst: n*, (2) *hm ntr Hr Thnw(?) kst-ε, wr idt*, (3) roughly blocked in, *irr mrnt nb-f r n nb*, (4) *imshw n nb-f*, (5) *nb imsh hr ntr* ♂ and in front of face *Shm-k*. In front of man, two registers of small figures: (1) figure standing facing to left holding papyrus in both hands, labelled above *rdit sš ndt hr*; (2) two figures standing facing to left: (a) with ewer and basin, *hm k ir cnt N-špsš-nswt* (cf. statuette found in chapel of G 4410); (b) with wicker basket on shoulder, *hm k* . . . (two daggers in case), *hm k Ttw* (identical with owner of G 4420, see Fig. 308).

South door-jamb: outer part destroyed; large standing figure facing out to left, with staff and wand; short wig, broad collar, panther skin over short skirt; between staff and man a small naked girl with right hand on breast and left hand hanging . . . (*st*)-*f Hnt-ksw-s*; above five vertical lines with titles as on north with the addition of 'wbs-priest of Inpw' in place of 'priest of Horus' and *wr idt*.

Serdab: small E-W serdab behind south *ka*-door of room (a) and connected with it by slot; 0.85 × 1.15 m.; area, 0.94 sq. m.; found empty.

Shaft G 4411 A: one shaft west of chapel against south end of G 4420; 1.3 × 1.35 m.; —5.9 m. in rock; lined with masonry on east, south, and west, 4.8 m.; 14 courses.

Chamber: type 4 b (1); on north (slightly askew); 3.2 × 2.45 m. and 2.0 m. high; area, 7.84 sq. m.; capacity, 15.68 cu. m.

Passage: 1.0 × 1.05 m. and 2.0 m. high.

Blocking: completely removed.

Coffin: white limestone coffin without lid; outside, 2.35 × 0.77 and 0.72 m. high; inside, 2.0 × 0.42 m. and 0.46 m. deep.

Completely plundered.

G 4411 was closely connected with G 4410; the position of G 4411 shows that it may have been built as an addition to G 4410; the *hm-k* Ne-shepses-nesuwt appears on the north door-jamb of G 4411 chapel and on a small statuette in the offering-room of the exterior stone chapel of G 4410, which was of u-masonry and later in date than the masonry used in G 4411, which was nearly contemporaneous with the masonry of G 4410; each mastaba has a shaft with large burial-chamber, both of the same type 4 b (1), each containing a white limestone coffin; the chamber in G 4410 is a little larger; they appear to have been made by the same workmen; the larger size of the chamber in G 4410 indicates that he or she was the more important person. Thus G 4410 may have belonged to an unnamed person and G 4411 to his son, or alternatively, G 4410 may have belonged to Sekhem-ka and G 4411 to his wife: I consider the latter suggestion as more probable and would reconstruct the stages in the building of the two mastabas by Sekhem-ka as follows:

- (1) He reconstructed the old core G 4410 into a mastaba of type IX a (1) with one shaft.
- (2) He built G 4411 of nearly the same masonry as an addition containing the shaft intended for his wife; in this he made an interior chapel of white limestone, of which the doorway was decorated in his name, probably intended to serve for the funerary services of himself and wife.
- (3) He added an exterior vestibule corridor of nummulitic limestone to the offering-room of G 4411; left undecorated.
- (4) Finally he or some one else constructed the exterior stone chapel against the east face of G 4410 and cut the subsidiary niche in the north end of the façade of that mastaba; the serdab of that chapel is much larger than that in G 4411.

I thus conclude that the chapel of G 4411 was constructed to serve the funerary services of both persons buried in the complex mastaba: that Sekhem-ka was buried in shaft G 4410 A and his wife in G 4411 A.

It is to be noted that the *hm-k3 Ttw* represented on the north door-jamb of G 4411 may be identified with the Tetuw of G 4420; in that case the use of G 4420 by Tetuw was later than the burials in G 4410 and G 4411, and this conclusion is borne out by the type and small size of the burial-chamber and by the cheap finishing of the old core. The names and titles of both Ne-shespes-nesuwt and Tetuw were apparently incised later than the reliefs in G 4411.

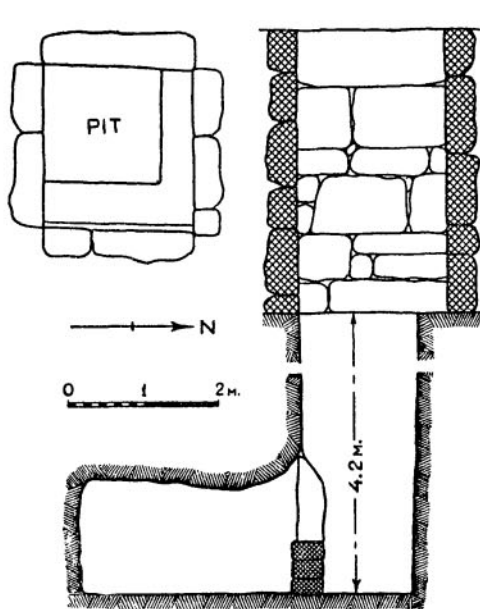

Section A-B

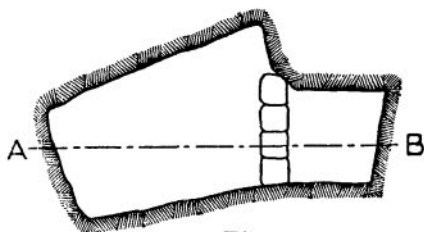
Plan
Fig. 320. G 4510 A

G 4510: row 1, line 5:

See Map 6 and Figs. 320 (shaft), 321 (objects).

See Pl. 72 b.

Excavated: January 17th and December 11th-12th, 1915.

Mastaba: core type IV-i; not cased; 23.5 × 10 m.; area, 235.0 sq. m.; prop. 1/2.35; h. 3.7 m., 3-4 courses.

Chapel: the usual place of the chapel is taken by a N-S passage which gives a circuitous entrance to the chapel of G 4516; the street is filled by later mastabas, but on the west side underneath were exposed older rubble walls belonging to a rubble chapel of type (1 d), partly destroyed:

(a) N-S offering-room appears to have been against the middle of the east face of the mastaba; about 4.75 × 1.4 m.; area, 6.65 sq. m.; prop. 1/3.39; entered from east by doorway in north end of east wall.

There are two other low-lying walls which could not be identified and may not belong to the chapel.

Shaft G 4510 A: sole shaft; 2.0 × 2.15 m.; lined with massive masonry 3.7 m.; 6 courses; smaller rock-cut shaft in SW corner; 1.55 × 1.5 m.; -4.2 m. in rock.

Chamber: type 6 b (1); on south; 3.0 × 1.9 m. and 1.45 m. high; area, 4.8 sq. m.; capacity, 6.96 cu. m.

Blocking: exterior leaning masonry wall bound with mud; type IV c (2); broken by thieves.

Plundered: a small number of objects scattered in thieves' debris partly in shaft and partly in chamber.

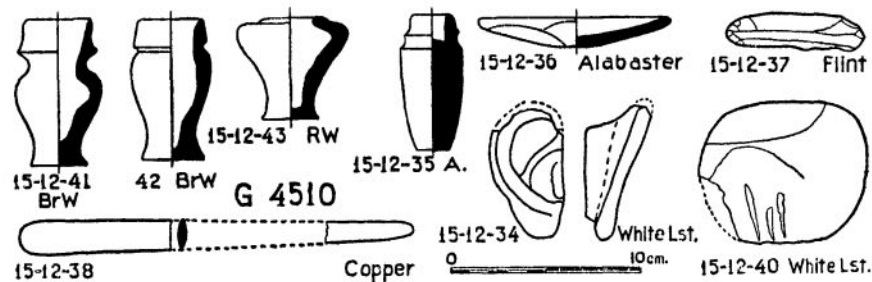

Fig. 321

15-12-34: w. lst.; ear of life size from a portrait head of a statue; back dressed flat to fit side of head; h. 6.9+ cm.; w. 3.8 cm. Fig. 321.

15-12-35: alab.; model collar jar, dummy; type S-XVI a-m; h. 7.2 cm.; d. top, 2.3 cm.; d. collar, 2.5 cm.; d. body, 3.6 cm.; d. base, 1.8 cm. Fig. 321.

15-12-36: alab.; model bowl with flat bottom; type S-X a (1); h. 1.6 cm.; d. 5.2 cm.; d. base, 1.0 cm. Fig. 321.

15-12-37: flint flake; length 7.2 cm.; w. 1.9 cm. Fig. 321.

15-12-38: copper; model blade with both ends rounded (butt wider than tip); two disconnected ends; length, 8.0+4.8 = 12.8+ cm. with a probable length of c. 20 cm.; w. butt 1.8 cm.; w. near tip, 0.6 cm. Fig. 321.

15-12-39: copper; model saucer; d. 12.2 cm.

- 15-12-40: w. lst.: irregular ball with scratched surfaces: h. 7.6+ cm.; d. 8.2 cm. Fig. 321.
 15-12-41: BrW; model collar jar, type B-LVI a; h. 7.9 cm.; d. top, 3.6 cm.; d. collar, 4.2 cm.; d. body, 4.6 cm.; d. base, 3.0 cm. Fig. 321.
 15-12-42: BrW; degenerate model jar, type B-XLIX b; h. 7.5 cm.; d. collar, 3.6 cm.; d. body, 4.2 cm.; d. base, 3.4 cm. Fig. 321.
 15-12-43: RW; 2 models of neckless shoulder-jar, type B-LV b-m; h. 5.4 cm.; d. rim, 3.6 cm.; d. max., 6.0 cm.; d. min., 2.6 cm.; d. base, 3.2 cm. Fig. 321.
 15-12-44: RW; 2 model saucers of type LXXIX a.
 15-12-45 a: RP; frags. of two or more large basins with tubular spout, type D-XXXV a; d. 30-40 cm.
 15-12-45 b: RP; round-bottomed bowl with high recurved rim; type C-XXXII b; d. 20 or more cm.

Later Constructions:

The street, the avenue, and the space south of G 4510 are occupied by small and medium mastabas of the secondary cemetery; the street east of G 4510 is divided by an E-W wall faced with u-masonry on the south, which crosses the street from west to east just south of the rubble chapel of G 4510.

North of this cross wall stand, from south to north, G 4515, G 4514, and against the north end of G 4510 stands G 4518 and west of it G 4511.

South of the cross wall ran an E-W corridor, probably roofed, which in the east end connected with the N-S corridor of G 4516 and on west entered another N-S corridor extending to the end of G 4510, where it entered the chapel of G 4513; this corridor was certainly roofed. Thus the chapels of G 4516 and G 4513 were clearly connected and walled off from the northern area.

South of the cross wall stand G 4516 on north and G 4512 on south; G 4517 was built against the south end of G 4512; G 4513 stands west of G 4512, built against the south end of G 4510; with portico chapel opening on a roofed corridor opening into winding corridor giving access to G 4516 and entered from south; G 4519 stands west of G 4513, built against the south end of SW corner of G 4510.

Of the northern mastabas, G 4514 was probably the earliest; all the southern mastabas were separated from this and the other northern mastabas by the cross wall and were certainly late in date; the southern mastabas appear to have been built in the following order: (1) G 4516, (2) G 4512, (3) the cross wall and the connecting passage, (4) addition G 4517 to G 4512, (5) G 4513, and (6) G 4519.

G 4610: row 1, line 6:

See Map 6 and Figs. 322 (shaft), 323 (objects).

See Pls. 72 c-e, 74 a.

Excavated: March 11th-22nd, 1914; November 14th-23rd, 1915.

Mastaba: core type IV i, not cased; 23.0 × 10.0 m.; area 230.0 sq. m.; prop. 1/2.3; h. 4.15 m., 3-4 courses.

Chapel: the east face of the core is covered with later structures, with G 4612 over the usual place of an exterior chapel; thus no trace of a chapel was found but there was probably a one-roomed rubble chapel of type (1 d).

Shaft G 4610: sole shaft; 2.1 × 2.1 m.; lined with massive masonry, 4.15 m., 5 courses; smaller rock-cut shaft in NW corner, 1.7 × 1.75 m.; -5.15 m. in rock; above the smaller shaft is lined with rubble resting on rock ledge, carried up to a height of 0.95 m. above rock.

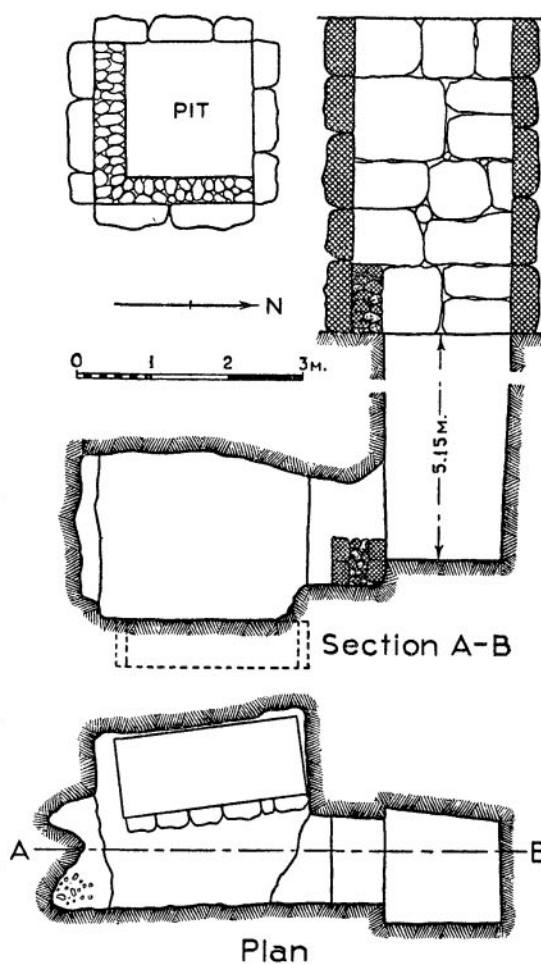

Plan
Fig. 322. G 4610 A

Chamber: type 4 b (1); on south; 2.9 × 2.35 m. and 2.2 m. high; area, 7.25 sq. m.; capacity, 15.95 cu. m.; roof irregular, sloping up to south.

Passage: 0.95 × 1.1 m. and 1.3 m. high; rough sloping step down from floor of passage to floor of chamber, 0.45 m. step down from shaft to passage, 0.3 m.

Blocking: interior blocking of two walls of masonry bound with plaster and filled between with rubble; type II b (1); filled upper part broken out.

Coffin pit: along west side; 2.45 × 1.05 m. and 0.65 m. deep; lined on east side with masonry set in plaster.

Plundered: in thieves' debris, a skull and scattered objects with large group of alabaster models.

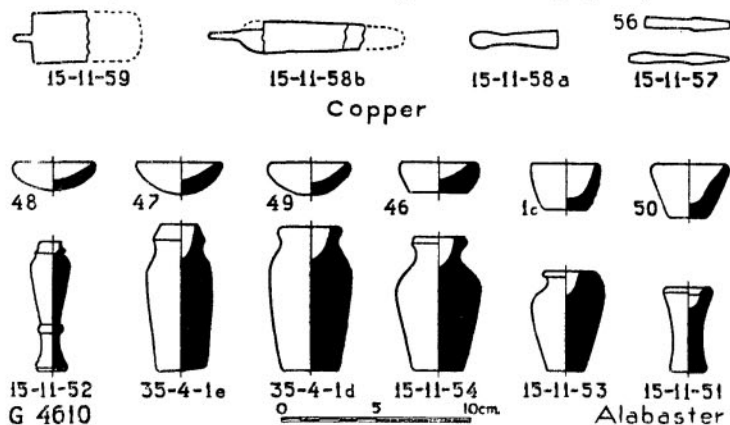

Fig. 323

Objects: found in thieves' debris on floor of chamber.

Type S-I d: cylindrical jar with concave sides; 4 examples:

15-11-51: alab.; dummy, rim not clearly marked; 2 examples; h. 4.5 cm.; d. top, 2.6 cm.; d. min., 1.6 cm.; d. base, 2.0 cm.; (b) h. 3.9 cm.; d. 2.3 cm. Fig. 323.

35-4-1 f: alab.; like 15-12-51; (a) h. 4.6 cm.; d. top, 2.2 cm.; d. min., 1.6 cm.; d. base, 2.1 cm. Pl. 74 a (4/3); (b) h. 4.0 cm.; d. 2.2 cm.; Pl. 74 a (4/7).

Type S-XIV b: model one-handled jug with unpierced handle; 1 example:

15-11-53: alab.; h. 5.3 cm.; d. rim, 2.4 cm.; d. body, 3.6 cm.; d. base, 1.8 cm.; w. with handle, 3.8 cm. Fig. 323.

Type S-XV a: model shoulder-jar with neck; 4 examples:

15-11-54: alab.; h. 7.1 cm.; d. rim, 3.0 cm.; d. neck, 2.4 cm.; d. body, 4.6 cm.; d. base, 2.8 cm. Fig. 323.

15-11-55: alab.; h. 7.5 cm.; d. rim, 3.2 cm.; d. neck, 2.6 cm.; d. body, 4.0 cm.; d. base, 2.4 cm.

35-4-1 d: alab.; 2 examples; (a) h. 7.5 cm.; d. rim, 3.4 cm.; d. neck, 3.0 cm.; d. body, 4.4 cm.; d. base, 3.0 cm.; (b) h. 7.7 cm.; d. rim, 2.9 cm.; d. body, 4.9 cm.; d. base, 2.9 cm. Pl. 74 a (4/5, 6), Fig. 323.

Type S-XVI a: model collar jar; 1 example:

35-4-1 e: alab.; h. 7.7 cm.; d. top, 2.2 cm.; d. collar, 2.8 cm.; d. body, 3.6 cm.; d. base, 2.7 cm. Pl. 74 a (4/4), Fig. 323.

Type S-XVI b: model collar jar, slender, on ring-stand; 4 examples:

15-11-52: alab.; 4 examples; h. 5.9-7.1 cm.; d. 2.1-2.6 cm.; (a) h. 6.8 cm.; d. top, 1.2 cm.; d. collar, 1.6 cm.; d. body, 2.0 cm.; h. ring-stand, 1.0 cm.; d. bottom, 1.4 cm. Fig. 323.

Type S-IX a: models of round-bottomed bowls of shallow form; 35 examples:

15-11-47: alab.; 4 examples; h. 1.4-2.1 cm.; d. 3.8-4.6 cm.; (a) h. 1.7 cm.; d. 4.6 cm. Fig. 323.

15-11-48: alab.; 8 examples; h. 1.1-1.4 cm.; d. 3.4-4.5 cm.; (a) h. 1.5 cm.; d. 4.3 cm. Fig. 323.

15-11-56: alab.; h. 1.4 cm.; d. 4.0 cm.

35-4-1 a: alab.; 22 examples; h. 0.9-1.9 cm.; d. 3.3-5.4 cm.; (a) h. 1.85 cm.; d. 5.35 cm. Pl. 74 a (rows 1 and 2).

Type S-X a (1): model basins with diam. over twice the height; 5 examples:

15-11-49: alab.; 5 examples; h. 1.3-1.7 cm.; d. 3.8-4.8 cm.; (a) h., 1.6 cm.; d. top, 4.0 cm.; d. base, 1.3 cm. Fig. 323.

Type S-X a (2): model basins with diameter less than twice the height; 19 examples:

15-11-50: alab.; 4 examples; h. 1.9-3.1 cm.; d. 3.6-5.1 cm.; (a) h. 2.9 cm.; d. 3.9 cm.; d. base, 2.0 cm. Fig. 323.

35-4-1 b: alab.; 13 examples: h. 1.4-2.8 cm.; d. 3.1-3.8 cm.; (a) h. 2.8 cm.; d. top, 3.8 cm.; d. base, 2.6 cm.

Pl. 74 a (3/1-4, 6, 8-11: 4/1, 2, 8, 9).

35-4-1 c: alab.; 2 examples; h. 2.4 cm.; d. 3.7 cm.; d. base, 2.0 cm.; (b) h. 2.4 cm.; d. top, 3.6 cm.; d. base, 2.2 cm.

Pl. 74 a (3/5, 7), Fig. 323.

Type S-X b: model basin with convex sides; 8 examples:

15-11-46: alab.; 8 examples: h. 1.3-2.0 cm.; d. 2.9-4.3 cm.; (a) h. 1.5 cm.; d. max. 3.9 cm.; d. base, 3.1 cm. Fig. 323.

SUMMARY: stone models, alabaster:

Jars: type I d, 4; XIV b, 1; XV a, 4; XVI, 5; total jars, 14.

Round-bottomed bowl: type IX, 35 models.

Basins with flat bottoms: type X a (1), 5; X a (2), 19; X b, 8; total 32 examples.

Sum total of models, 81 examples of which 14 were jars and 67 basins and bowls.

Copper model tools: 8 models (4 chisels, 2 adzes, 1 knife, 1 razor).

15-11-56, 57: copper, 4 models of broad chisel; length, 4.6-6.9 cm.; w. 0.5-0.6 cm. Fig. 323.

15-11-58 a: copper; 2 model adzes; length, 4.6 cm.; w. edge, 4 mm.; w. butt, 4 mm. Fig. 323.

15-11-58 b: copper; model of knife with haft; incomplete; length, c. 10.2 cm.; w. max., 1.6 cm. Fig. 323.

15-11-59: copper; rectangular razor with shaft on butt; incomplete; length, 3.8+ cm.; w. 2.8 cm. Fig. 323.

Miscellaneous Objects:

15-11-60: gold; frag. of thin gold leaf; 7.5 × 1.2 cm.

15-11-61: BrW; frag. of rim of shallow dish with rim moulded (perhaps type LXIII a); 11.3 × 10.4 cm.

Later Constructions:

The later constructions are dominated by G 4611, a large mastaba of net area 108.8 sq. m.; type VIII c with decorated interior chapel of type (5 a) of man named *Niwty*; this mastaba fills the south end of the street east of G 4610 and extends southwards into the avenue south of row 1; the small mastabas, G 4612, G 4613, and G 4614-5 are certainly late in date; all of Dyn. VI.

G 4612: a small stone mastaba built against the east face of G 4610 at south end and against the north end of G 4611.

G 4613: small stone mastaba built against the east face of G 4611 (north of doorway to chapel) and against the south end of G 4710 near SW corner.

G 4614: small stone mastaba west of G 4611 with passage between and built against the south end of G 4610; earlier than G 4512-4516, west of it.

G 4615: small destroyed stone mastaba built against the south end of G 4614.

G 4616: in avenue north of G 4610: small composite mastaba partly of c.b. and partly of rubble: built against the south end of G 4620.

G 4710 = L. G. 49: row 1, line 7; last core in row:

See Map 6 and Figs. 324 (shaft), 325 (objects).

See Pl. 72 f, 73 a-c; 74 b to d, 75 a, b.

Excavated: March 6th-10th, 1914; November 20th-24th, December 4th, 1915.

Owner: Sethuw, *šmr wcty*, *hry čh*, *hry ššt*; *n pr Dwt*, *hry wdb ht-cnḥ*, *hry tp Nḥb*.

Mastaba: core type IV-i, with recess broken out for interior chapel and cased with nummulitic masonry converting the mastaba into type VI a; the core could not be measured; final mastaba, 24.6 × 11.6 m.; area, 285.36 sq. m.; prop. 1/2.12; h. 4.5 m.

Chapel: interior one-niched offering-room of type (3 a) built partly of white limestone and partly of nummulitic (mixed); with subsidiary north niche; with exterior c.b. chapel of type (1 f) containing three rooms (b-d).

(a) N-S offering-room of type (3 a); 3.15 × 1.15 m.; area, 3.62 sq. m.; prop. 1/2.74; relation, 1/78.82; with niche near south end of west wall; entered from east from room (b) by doorway in north end of east wall; decorated in relief.

(b) in c.b.: large N-S hall around doorway embrasure of room (a); 4.55 × 2.6 m.; area, 11.83 sq. m.; entered from east from room (c) by doorway in north end of east wall; in SE corner an offering-table with slab removed.

(c) of c.b.: N-S vestibule corridor; 4.3 × 1.0 m.; area, 4.3 sq. m.; entered from east by doorway in middle of east wall; in SE corner, a compound niche facing to west, built later against the east and south walls of the room; doorway to room (b) in north end of west wall; doorway to magazine (d) in north wall.

(d) of c.b.: E-W magazine north of rooms (b), (c); 1.55×4.4 m.; area, 6.82 sq. m.; entered from (c) by doorway in east end of south wall.

Total area, (b)-(d), 22.95 sq. m.

Total area, (a)-(d), 26.57 sq. m.

Decoration of Inner Offering-room (Lepsius, *Denkmäler*, Pls. 86 b, 87; *Ergänzungsband*, pl. xxvii b):

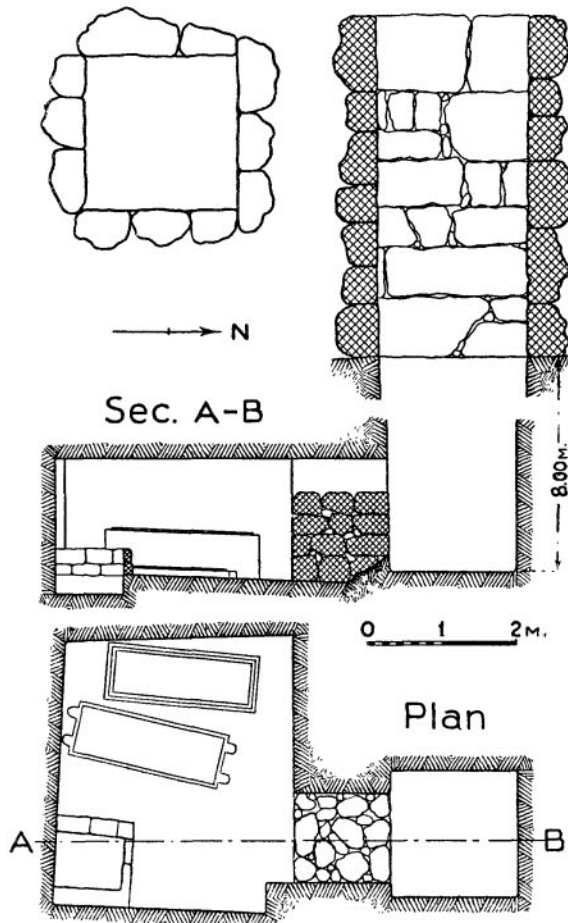

Fig. 324. G 4710

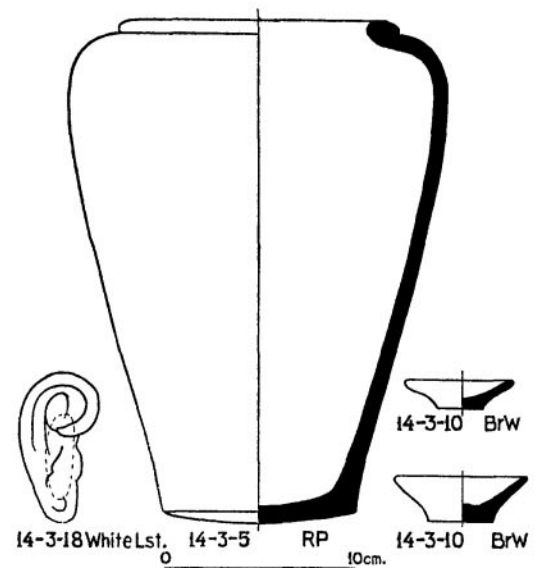

Fig. 325. G 4710

West wall: south *ka*-door (Architrave and part of *ka*-door in Berlin Museum; tablet in the Brooklyn Museum, from the Collection of the New York Historical Society):

Architrave: offering formula, titles and name in short vertical lines: *dī nswt ḥtp, rdī Inpw ḥtp, ḥnty šh ntr, krs, m smyt imnt-t, nb imšh*, titles and name.

Tablet: Sethuw seated at table of bread facing to right; short wig and long robe; left hand on ties of robe and right extended to table; ideographic list under table; above the table is a row of vertical lines containing the short list and to the right of the table are five rows of vertical lines continuing this list: all read from right to left with signs facing to right: upper row, (1) *sntr*, (2) *wḏw*, (3) *mšdmt*, (4) *štī-ḥb*, (5) *ḥknw*, (6) *nhnm*, (7) *sft*, (8) *ḥtp nswt*, and below *ḥtp nswt wšht*. See Pl. 74 b.

Tablet, flange on right (north): woman standing facing to left; lappet wig and long tunic; right hand on breast and left hanging open: labelled *ḥm ntr Ht-ḥr, ḥm ntr Nt wpt wswt mḥt-t inbw, rḥt nswt Nb-ḥtp*, wife of Sethuw.

Tablet, flange on left (south): two figures; above a naked boy with finger to mouth, standing facing to right, labelled, *rḥ nswt sḏ-f Stw*; below, a girl stands facing to right, with left hand on breast and right hanging, labelled, *rḥt nswt Pth-ḥp-kḏ*.

Crossbar: signs facing to right: *dī nswt ḥtp Inpw ḥnty šh ntr krs m smyt imnt-t nb imšh iḥw nfr wrt prt-ḥrw rc nb ḥb (nb) . . ., smr, ḥrp ch Stw*.

Drum: *šmr wcty, hrp ḥ, hry ššt n pr dwst, hry wdb ht-cnḥ Stw.*

Inner niche not decorated.

Back of outer niche: on left (south); Sethuw standing facing in to right, with staff and wand; short wig, short skirt; amulet on neck; above, titles and name in three short vertical lines.

Back of outer niche: on right (north); wife standing facing in to left with right hand on breast and left hanging open; lappet wig and tunic; above, titles and name in four vertical columns: (1) *rht nšwt*, (2) *hm ntr Ht-hr*, (3) *hm ntr Nt*, (4) *Nb-Htp*; in front of her, small naked boy facing to left, *sf n ht-f Stw.*

Side of outer niche: on left (south); vertical row of three men, standing in respectful attitudes facing in to right: (1) arms folded on breast, *š šn-dt Tnti*; (2) with arms crossed on breast; (3) with arms hanging at sides.

Side of outer niche: on right (north); three standing men in vertical row, facing in to left; (1) censuring, *kḥp sntr*; (2) man leaning over and holding cup (?) over basin on stand; (3) man in similar attitude to (2).

West wall: north of *ka*-door; presentation scene (Pl. 75):

Large standing figure of Sethuw at north end of wall facing to left; with staff and wand; short wig, short skirt and panther skin; inscribed above in three short vertical lines: *šmr wcty, hrp ḥ, hry tp Nhb Stw.*

To the left of Sethuw, four registers of figures facing to right: (1) two scribes, three men bringing animals, and ten estates, alternately female and male; the register continues to the south over the architrave of the niche (now missing); names of estates not given; (2) two men making libation or purification with water; three men bringing food-offerings; (3) man heads a procession of five others bearing mainly personal equipment; (4) four men carrying live birds, three carrying young animals, and the eighth man a ewer and basin.

North, south, and east walls: not decorated.

Door-jamb on north (upper part now destroyed, Pl. 74 c, cf. Lepsius, *l.c.*, Pl. 86 b): Sethuw seated at table of bread facing out to right; short wig, collar and long robe; left hand on shoulder tie and right hand extended; above five vertical lines: (1) *dī nšwt htp prt-hrw r nb hb nb*, (2) *Dḥwtyt Wg ibd . . . nt*, (3) *rkh prt-Mnw wšh ḥ*, (4) *šmr wcty hry ššt pr dwst*, (5) *hrp ḥ Stw*; under table ideographic list (bread, beer, and cakes, head of oryx and calf, ointment and linen). To the right of the table two registers:

(1) one standing figure facing to left in *hry wdb* attitude, labelled *hry-wdb wd iht* (det. bread, beer, and cakes).

(2) two figures: (a) kneeling on left knee with right arm raised, bent at elbow and fist clenched, *šmnt šh wt*; (b) kneeling on left knee, holding out a cake in right hand and a *nw*-pot in left, *wdpw hnty wr*.

Door-jamb on south (upper part now destroyed, Pl. 74 c, cf. *op. cit.*, Pl. 86 d): Sethuw seated at table of bread facing out to left; short wig, collar, and *hry-hb* sash; short skirt; above four vertical lines, facing to left; (1) *dī nšwt htp prt-hrw* as on north, with shorter list of festivals; under table ideographic list (bread, beer, cakes, ointment and linen, head of bull, calf, and two birds); on the left of the table a small figure standing facing to right, holding out basin in right hand and holding a pellet of natron (?) between fingers of left hand over the basin.

Drum over entrance doorway (now missing): in seven vertical lines: (1) *šmr wcty hrp ḥ*, (2) *hry ššt*, (3) *n pr dwst*, (4) *hry tp Nhb*, (5) *imšh*, (6) *hr nb-f*, (7) *Stw*.

Architrave over entrance (now missing): on left end (south) seated figure facing to right with left hand on breast and right hand half extended; short wig, long robe (?); offering formula in sixteen vertical lines: (1) *dī nšwt htp*, (2) *Inpw hnty šh ntr*, (3) *hrs*, (4) *m smyt imnt-t*, (5) *nb imšh*, (6) *hr ntr c*, (7) *iw nfr wrt*, (8) *prt-hrw r nb*, (9) *šmr, hrp ḥ*, (10) *hry tp Nhb*, (11) *(hry tp) dšt*, (12) *hry ššt*, (13) *pr dwst*, (14) *hry wdb ht-cnḥ*, (15) *nb imšh*, (16) *Stw*.

Shaft G 4710 A: sole shaft; 2.05 × 2.05 m.; contracting to 1.7 × 1.7 m.; at bottom; —8.0 m. in rock; lined above with massive masonry, 4.5 m.; large and small blocks irregularly set.

Chamber: type 4 a (2) x; on south; 3.1 × 3.6 m. and 1.6 m. high; area, 11.16 sq. m.; capacity, 17.85 cu. m.

Passage: 1.25 × 1.2 m. and 1.25 m. high on shaft side and 1.65 m. on chamber side owing to sloping floor.

Blocking: interior rough stones and rubble set in plaster type II cd (1) apparently removed by thieves.

Coffin: along west side; white limestone coffin with flat lid (type d): outside, 2.0 × 0.73 m. and 0.6 m. high; inside, 1.8 × 0.53 m. and 0.5 m. deep: height of lid, 0.09 m.

Canopic pit: in SE corner, partly built and partly sunk in floor; 0.9 × 0.75 m. and 0.6 m. deep (—0.2 m. in rock).

Plundered: objects scattered on floor: frags. of human bones found in hard dust in coffin.

Objects: found intrusive in shaft:

14-3-17: alab.; frag. of foot of statuette; 8.1 × 5.0 × 3.5 cm.

Objects: found in thieves' debris partly in shaft and partly in chamber:

14-3-18: w. lst.: ear from head ('reserve-head' or statue), dressed flat on back, possibly attached with plaster; h. 6.9 cm.; w. 3.5 cm.; thickness, 2.0 cm. Found in chamber. Pl. 69 f. Fig. 325.

Pottery:

Group A:

Type A-II b: large wine jar; frags. of 1 example:

14-3-9: WSR: frag. from neck and top of body.

Group B: type B-LV b: neckless shoulder-jar; 2 large examples:

14-3-5: RP: 2 examples; h. 26.6 cm.; d. rim, 14.8 cm.; d. shoulder, 20.0 cm.; d. base, 10.2 cm. Fig. 325.

Group C:

Type C-XXVII: shallow dish with rim widened, flat on top; 2 examples:

14-3-8: BrW; frags., 2 of rim.

14-3-12: BrW; frag. of another deeper dish.

Type C-XXXII a: round-bottomed bowl with recurved rim; frags. of one or more:

14-3-6: RP; frags. of one or more.

Type C-LXI e: bowl with plain rim; 1 example.

14-3-7: RBrW; wet smoothed; frags. including rim.

Group D:

Type D-LXXIX a: model basins, shallow; 40 examples (20 incomplete):

14-3-10: BrW; 40 examples; h. 1.5-2.4 cm.; d. 5.9-6.9 cm. Fig. 325.

SUMMARY OF IDENTIFIED TYPES:

Group A: type II b, 1; total 1 jar.

Group B: type LV, 2; total 2 jars.

Group C: type XXVII, 2; XXXII, 1+, LXI e, 1; total 4+ examples.

Group D: type LXXIX, 40; total 40 model basins.

Sum total, 47+, of which 3 are jars, 4+ bowls, and 40 model basins; total types 6.

Unidentified pottery vessels:

14-3-11: RP; frags. of jar of type A-VI or B-XVII.

14-3-13: RW; frag. of rim perhaps type A-IV.

14-3-14, 15: 21 small frags. of various wares.

Later Constructions:

G 4711: a medium mastaba of z-masonry built against the east face of G 4710 north of chapel with passage left between it and north end of exterior c.b. chapel.

The core G 4810 was never built and the site east of G 4710 and G 4711 is occupied by a complex of mastabas numbered G 4811-4813; southwards the secondary cemetery is continued with small obscure mastabas, partly destroyed, numbered G 4814-4818.

West of these southern mastabas and south of 4710 and its exterior chapel stand two medium-sized mastabas on independent sites, G 4712 and G 4714; G 4712 belonged to a Queen Ne-ma'at-hap; G 4714, immediately east of G 4712, belonged to a Princess (*sit nswt nt ht-f*) Nefer-hetep-s; I would date both mastabas to Dyn. V between Neferirkara and Newesera or a little later, that is after G 4710 and before the complex G 4811-4813; against the east face of G 4714 north of the exterior c.b. chapel was built a small mastaba (G 4715) of a person related to Princess Nefer-hetep-s.

G 4712 a: a small destroyed mastaba with its SE corner overbuilt by G 4712.

G 4713: obscure rubble construction built against the north end of G 4714 and the back of G 4811; later than either.