

VI

THE BURIAL-SHAFTS OF THE FINISHED MASTABAS OF THE NUCLEUS CEMETERIES

THE finished mastaba ready for the burial included the completed burial-shaft and chamber, the casing, and the decorated chapel. Actually these represent three stages, but it appears that the three stages were so closely connected in time that they must be dealt with as one. That the excavation of the shaft in the rock below the mastaba-core was a later operation than the construction of the core is shown by the fact that in some cases the rock-shaft was never excavated, and in other cases a smaller shaft was excavated usually about one-quarter the size of the old 2-m. shaft. In a few cases the excavation of the shaft took place even after the decoration of the chapel.

The consideration of the date of the completion of the mastaba depends on the four different parts of the mastaba and is to be discussed as follows:

1. Type of burial-shafts and chambers.
2. Types of casing.
3. Types of chapel.
4. The decoration of the chapel.
5. Statues and *serdabs*.
6. Types of burials.

In this chapter I deal with the type-forms of the burial-shafts.

1. TYPES OF SHAFTS AND BURIAL-CHAMBERS

The burial-shafts of all the cores of types II, III, and IV in both the Eastern and Western Fields (Cems. G 1200, 2100, 4000, en Échelon, and 7000) have openings approximately 2 m. square. The upper part where the shaft passes vertically through the filling of the core is cased with masonry of the same type as the retaining wall of the core and is counted as part of the core construction. The lower part is excavated in the rock. On the south side, at the bottom of the rock-shaft, opens a short passage which leads to the burial-chamber through the north wall of that chamber near the eastern side. The chambers are rectangular and unusually high except for a few unfinished examples. In the SE corner is either a canopic pit in the floor or a canopic niche in the south wall. The coffin stood along the west wall, orientated N-S. The connecting passage, sometimes sloping, but more often horizontal, entered the chamber high up, in the middle of the wall, or near the floor. In all the early shafts the chambers were lined and paved with white limestone blocks but not roofed, being cut in sound rock. After the burial, the entrance passage was blocked with masonry of fine white limestone set in plaster (sulphate of lime), and over the opening, close against the southern wall of the shaft, was set upright a great slab of limestone (portcullis stone). In five cases in Cem. G 2100 a groove ran down the SE and SW corners of the shaft for the lowering of this great slab. This also served to prevent the stone being easily pulled back by thieves. The shaft after the burial was filled with gravel and rubbish or packed with small blocks of limestone (see the secret tomb of Hetep-heres I). We have no evidence that the

mouth of the shaft was blocked with masonry, except when the mastaba was roofed with stone (see 5230, 2100-annex).

In the light of the development of the substructure of the Egyptian tomb the origin of the lined chambers at Giza becomes clear. Originally the lining of the burial-chamber was a feature peculiar to the open-pit grave of the Predynastic period, and in these the lining was of wood resembling a box with an open bottom. With the introduction of the c.b. lined grave, the wooden lining developed on the one hand into a wooden coffin, and on the other into a more carefully constructed wooden lining. The open-pit type of grave continued to be lined with c.b. and roofed with wood and brick vaults, until the introduction of the deep underground burial-chambers. As early as the reign of Zer, an open-pit grave (type I B, Q S 2185) was lined and roofed with stone. The burial-chamber of King Khasekhemuwy at Abydos was lined with stone, and several of the deep stairway tombs had chambers lined with stone. The construction of a stone burial-chamber in a great open pit was introduced in the pyramid of Zoser. This type of substructure dominated the development of the royal tombs down to the accession of Cheops, and at Medum was introduced in private tombs in a modified form in the reign of Sneferuw. This Medum substructure consisted of a great open pit and trench in which was constructed a roofed stone chamber with a sloping approach also built of stone and roofed. The lined chambers approached by a shaft were directly derived from the sloping-passage type. At Medum in the bad rock of that site the chambers of the shaft type of substructure were either built in open pits or in cavities excavated in the bad rock, and in both these variations the chamber was necessarily roofed with stone. At the same time that such shaft-tombs were being constructed at Medum, Cheops was making the early tombs of his necropolis at Giza, but in these, owing to the sound rock, no artificial roof was necessary, and the rock chamber was merely lined and paved with white limestone. The other features of these Giza substructures, the shaft with portcullis slab, the connecting passage, the form of the burial-chamber, and the canopic niche or pit, were also employed in the contemporaneous shaft-tombs at Medum and Dahshur, and before this in the stairway tombs and in the sloping-passage tombs of the reign of Sneferuw.

a. The Classification of the Burial-shafts at Giza

The development of the substructure of Egyptian tombs has been traced in *Tomb Development* from the open-pit form of Dyn. I to the shaft type of the reign of Sneferuw (substructures types I-VI). The Giza forms are of type VI with a few examples of the later sloping-passage type of the Old Kingdom. All are here reckoned as of type VI, but for the sake of convenience the Roman figure is omitted and the variations are marked with Arabic numerals and letters.

The orientation of the long axis of the substructures of type I was N-S. When the stairway was introduced in type II, the general orientation (N-S) of the older tombs was maintained, but a few notable examples (the tomb of Wedymuw at Abydos) were orientated E-W. The stairway entered the main chamber more often from the long side, but occasionally from one of the short ends. The stairway ended in a doorway through the c.b. lining of the open pit, and the doorway varied in thickness with the thickness of that lining. The same variations appeared in type III, known only in Upper Egypt.

When the rock-cut substructure (type IV) was introduced at Memphis early in Dyn. II, the entrance from one end (usually the north) became almost obligatory. The complex of rooms was extended therefore in a N-S direction and the main rooms were N-S rooms entered from one end. The burial-chamber which contained the N-S burial-receptacle was also a N-S room, but was usually entered from

one side. Again, a few examples occur of an E-W burial-chamber with the burial-receptacle lying N-S along the west wall of the chamber.

When type V, the sloping-passage type, was introduced in the tomb of Zoser (Step Pyramid of Saqqarah), the open trench was of the T-form with a long, sloping passage descending from the north to a cross-trench (E-W) in which was built the actual burial-chamber. The examples include the two burial-chambers of the Zoser complex, the unfinished pyramid of Zawiet-el-Aryan, and a number of private tombs at Medum. In all these the burial-chamber is either N-S or E-W without apparent cause for the variation, except in the arbitrary desire of the owner. All these have a doorway or connecting passage between the approach and the chamber itself.

The Medum tombs with sloping-passage substructures are from the transition period from Dyn. III to Dyn. IV. At Saqqarah, in this period which ends in the full development of the shaft substructure (type VI), the chambers present again the N-S and the E-W forms often without doorway or passage. The early shaft-tombs also present the same variations. The larger and better shafts have a doorway or connecting passage.

It has been noted above that the burial apartments of the substructures of type IV were made on the south of the long stairway. The sloping-passage structure (type V) by its form necessarily had the burial-chamber on the south also. When the shaft-type VI came in as a substitute for types IV and V, it followed the practice of the older substructures and had the chamber on the south. The mastaba itself maintained the long proportions of the old mastaba with long N-S stairway or sloping passage, and the natural proceeding was to follow the old position of the burial-chamber on the south, approximately behind and below the chief offering-place. All the mastabas with substructures of types I-III had one burial-place in each. The mastaba of type IV also generally had one stairway, but a number were 'twin-mastabas' with two burial-places and two pairs of offering-places, bringing the burials of husband and wife into intimate association without resorting to *Sati* burial. The early shaft mastabas were also one-shaft or in a few cases 'twin-mastabas'. In all these the placing of the burial-chamber south of the shaft was both in accordance with previous practice and physically possible from the size and form of the mastaba. It was not until the multiple-shaft mastaba came into use and the greater part of the interior of the mastaba was taken up by shafts that the southern position of the chamber had to be abandoned in order to prevent the chambers from breaking into each other. The one-shaft and the 'twin-mastaba' were replaced in the reign of Chephren by the two-shaft mastaba with a single pair of offering-places. The multiple-shaft mastaba was used in family mastabas in the latter part of Dyn. IV. With the multiple-shaft mastaba the chamber began to be placed, as convenient, on the south, north, east, or west. Nevertheless, the south position continued to be used particularly for the chief burial-chamber.

When the whole series of chambers at Giza is examined, it is seen that the shafts present nine different types:

- Type 1: large lined chambers, always south of the shaft, entered by a long connecting passage at or near the east end of the north wall of the chamber; chamber lined and paved with fine white limestone dressed smooth, but not roofed (Fig. 19).
- Type 2: like type 1 but with a ramp or stair inside the chamber, leading from the floor of the passage to the floor of the chamber; linings designed, but in half the cases left unexecuted (Fig. 20).
- Type 3: like type 1 but unlined; high chambers (Fig. 21).
- Type 4: like type 3 with low chamber; roof-level of chamber at roof-level of passage; height of chamber as height of passage on inside, or with low step from floor of passage to floor of chamber, connecting passage not less than 0.5 m. in length (Fig. 22).

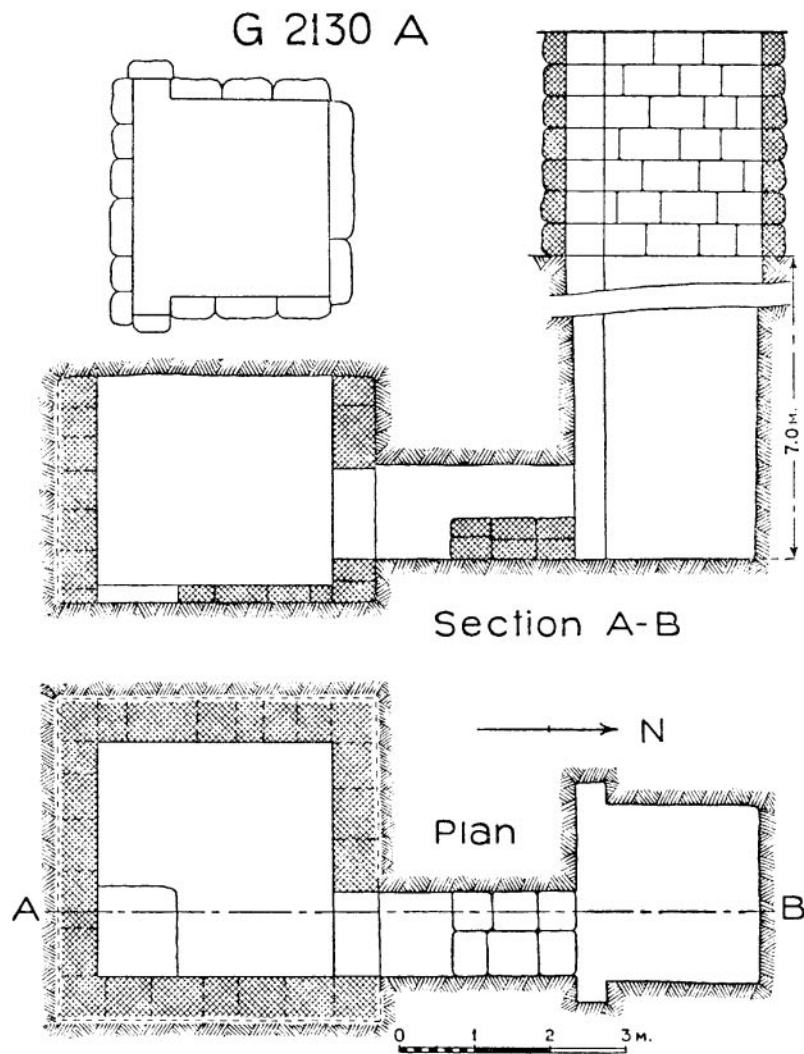

Fig. 19. Type I

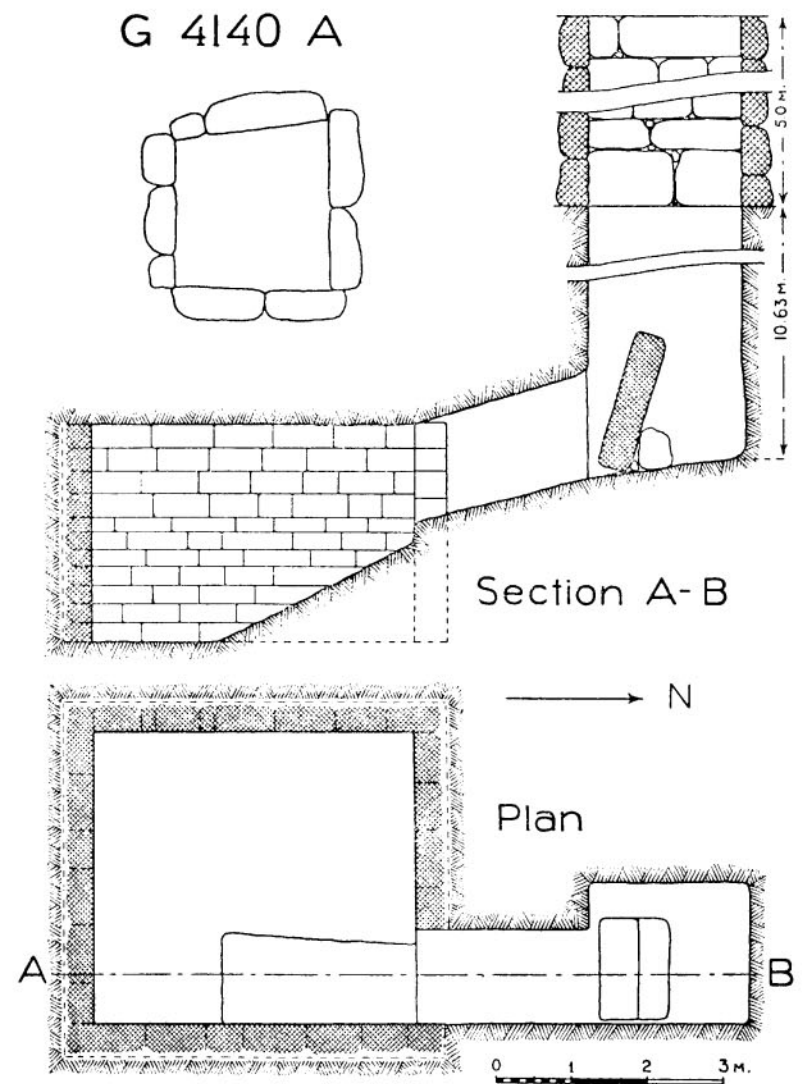

Fig. 20. Type 2

Type 5: short connecting passage or door-jambs between shaft and chamber less than 0.5 m. in length (Fig. 23).

Type 6: without connecting passage or door-jambs; chambers open directly into shaft (Fig. 24).

Type 7: open shaft with chamber constructed in shaft or with burial unprotected as in open-pit grave (Fig. 25).

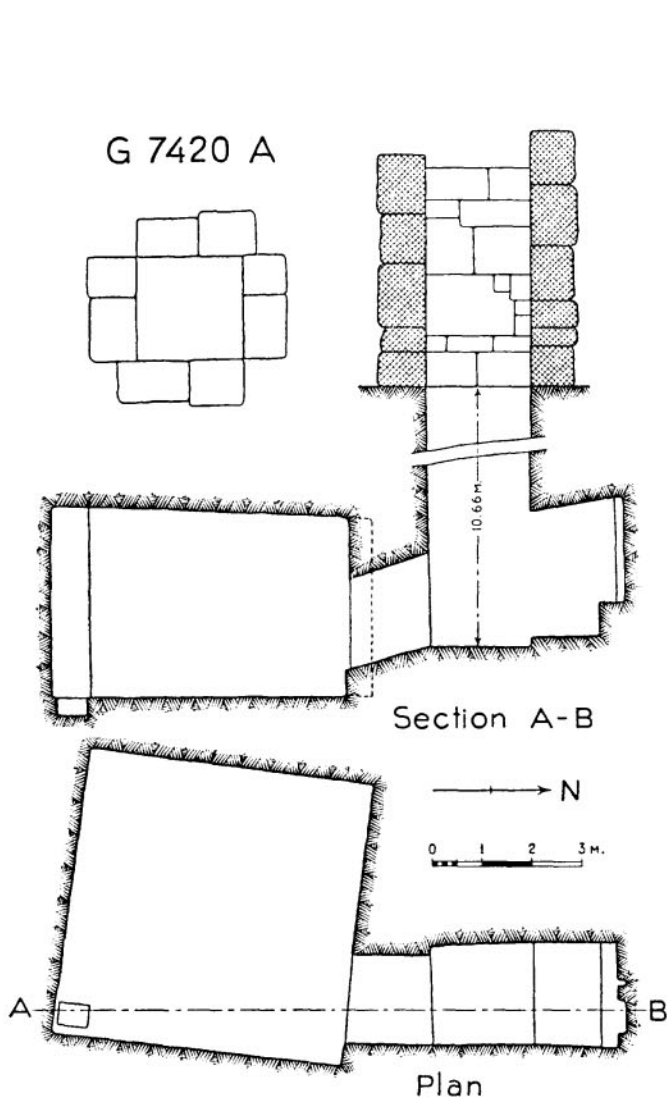

Fig. 21 Shaft type 3

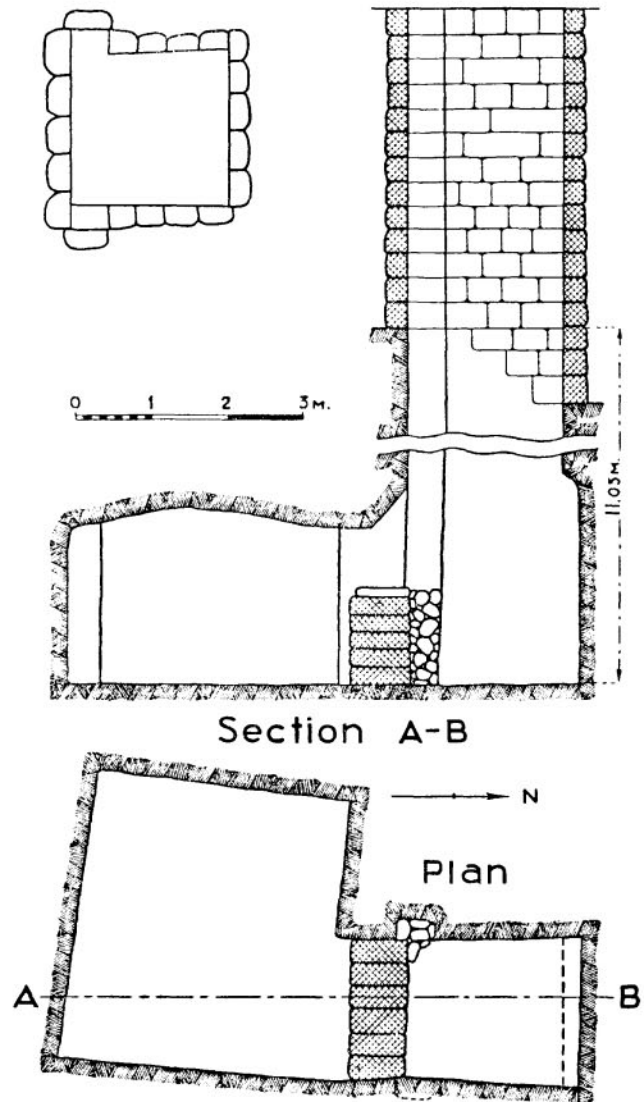

Fig. 22. G 2110 A

Type 8: built shaft and chamber which does not enter rock; forms as types 5 and 6 (Fig. 26).

Type 9: later sloping-passage type of Old Kingdom (Fig. 27).

The position of the chamber is always on the south in types 1, 2, and 3. It begins to be variable in type 4 but is usually on the south. In types 5 and 6 the position of the chamber may be on any side of the shaft. In type 7 the small roofed chamber in the shaft is almost always a N-S chamber, but may be in the middle of the shaft or against the east or the west side. Type 8 has the chamber north or south in a majority of examples, but may have it on any side of the shaft.

The types 1-6 and 8 present the two variations observable in all the earlier types, those with E-W axis and those with N-S axis. With the introduction of the chamber on the north, west, or east of

G 4430 A

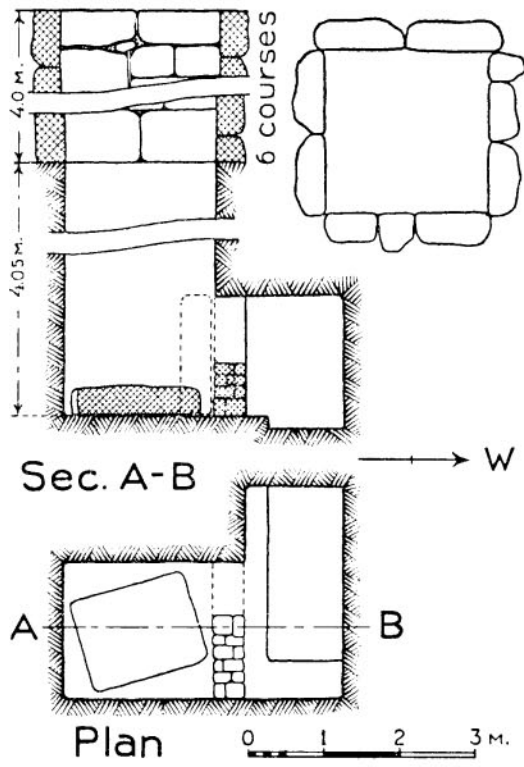

Fig. 23 Shaft type 5

G 4320 A (2)

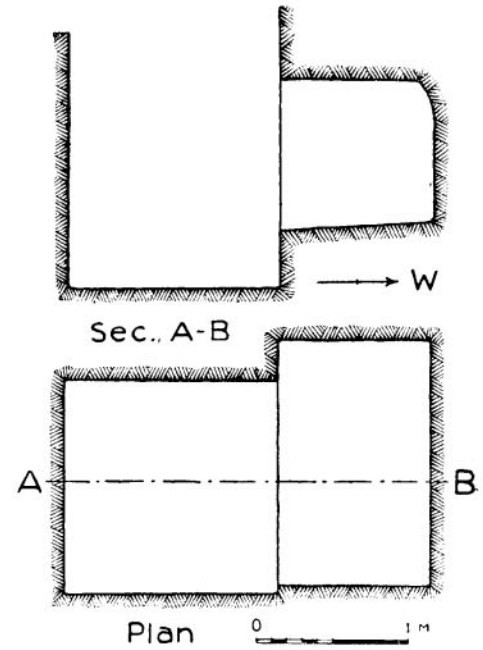

Fig. 24 Shaft type 6a(2)

G 1367 B

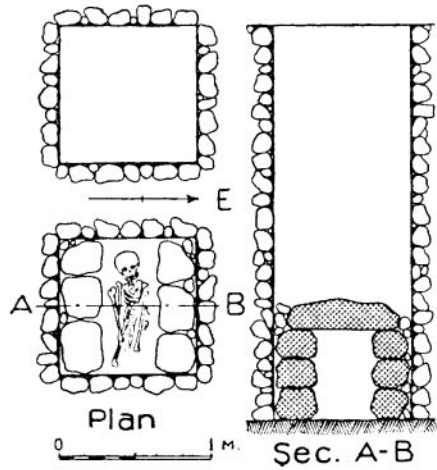

Fig. 25 Shaft type 7a

G 1362 C

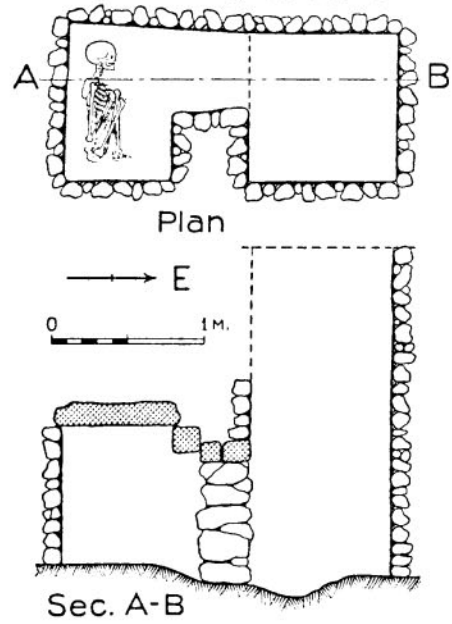
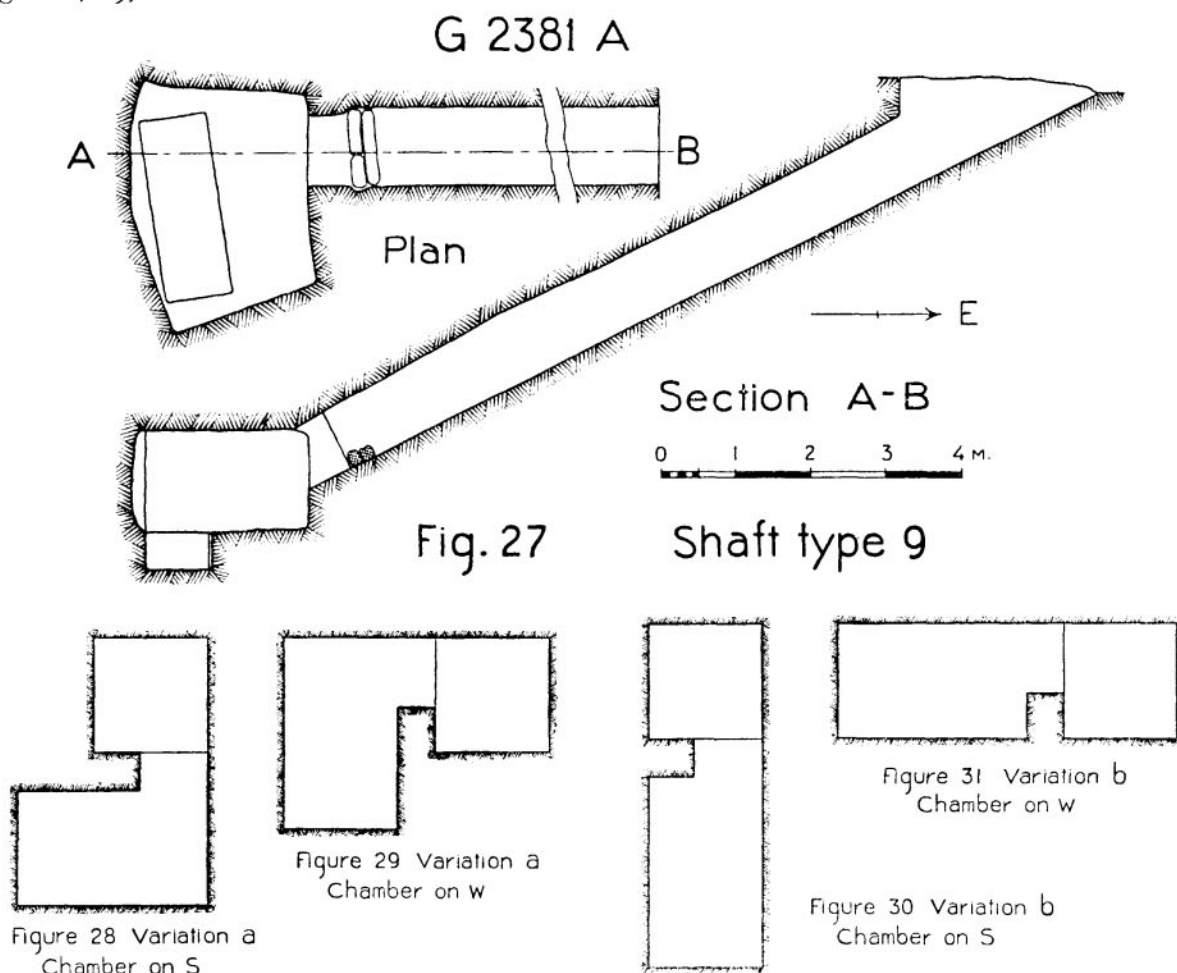

Fig. 26 Shaft type 8

the shaft, the old designation of N-S and E-W has to be modified, and I mark these two features as follows:

Variation a: chamber parallel to the adjoining side of the shaft; when the chamber is on the south or north, its long axis is E-W; when the chamber is east or west of the shaft, its long axis is N-S (Figs. 28, 29).



Variation b: the long axis of the chamber is at right angles to the adjoining side of the shaft; when the chamber is on south or north of the shaft, its long axis is N-S; when the chamber is east or west of the shaft, its long axis is E-W (Figs. 30, 31).

These two letters, 'a' and 'b', mean the same thing wherever used with types 1, 2, 3, 4, 5, 6, and 8. The letters 'c', 'd', &c., mark other variations which are not common to the types 1-6 and 8.

Variation c means—

- for types 1-3, a square or nearly square chamber.
- for type 5, a smaller chamber like type 5 a, with area less than 2.0 sq. m.
- for type 6, a recess chamber.

Variation d is used only for types 5 and 6 and means—

- for type 5, a small nearly square chamber about the same area as the shaft.
- for type 6, a recess chamber so small that the burial lies partly in the shaft protected by a constructed extension of the chamber.

Fourteen of the fifteen initial mastabas of the three nucleus cemeteries of the Western Field all present variations of type 1. The following twenty-five mastabas present types 1-3. The twin-mastabas

of the nucleus cemetery in the Eastern Field present type 3, and the later mastabas of Cem. G 4000 types 3-6. Dated mastabas of Dyn. IV present types 1-6, while those of Dyn. V vary from type 3 to type 6. It is clear that the types 1-6 were introduced in this order at Giza. The use of types 7 and 8 increases in the latest mastabas in the cemetery.

(1) *The Variations of Shaft Type 1*

As explained above, the old variations in the relation of the chamber to the shaft prevail throughout the examples of type 1, and are marked by the letters: 'a', for the E-W chamber on the south; 'b' for

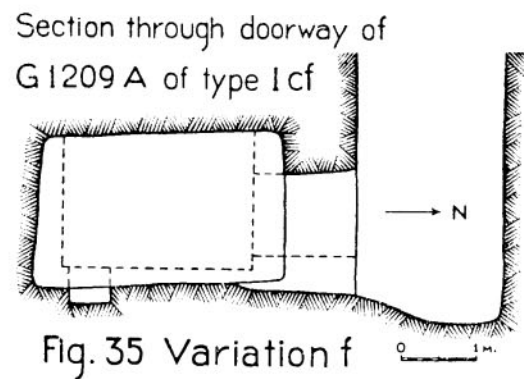
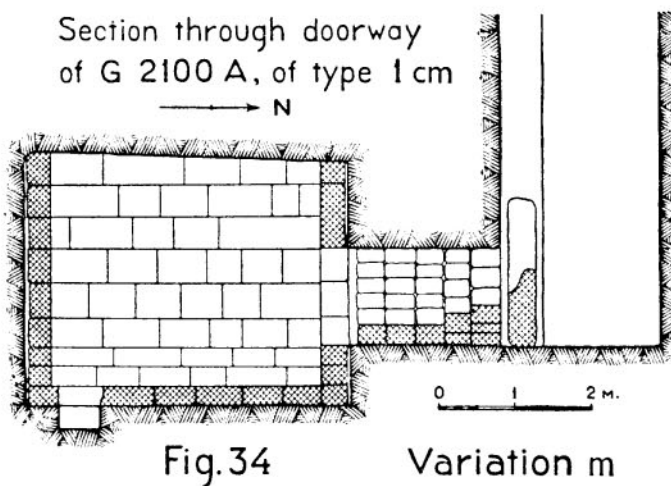
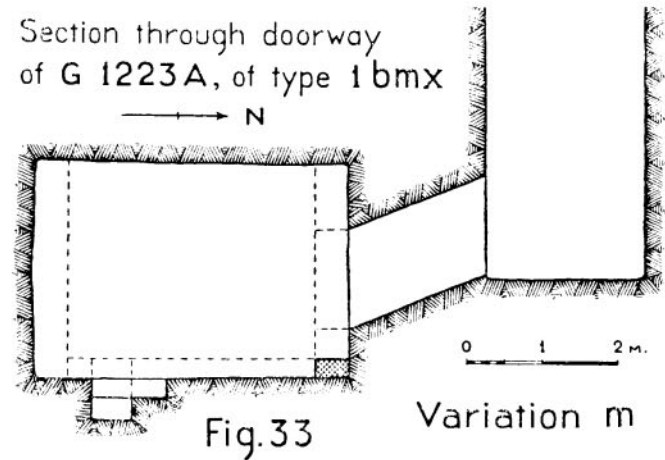
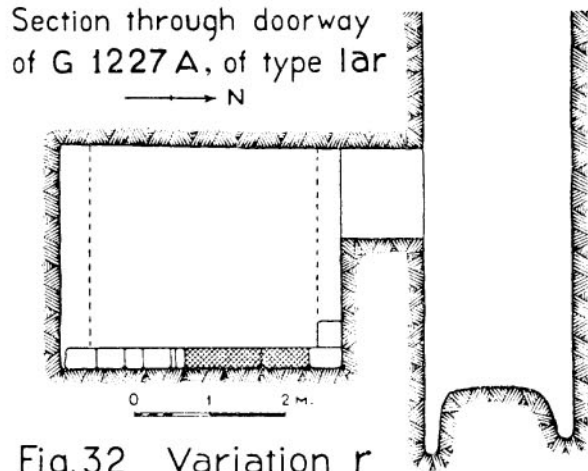

the N-S chamber on the south; and 'c' for the square or nearly square chamber on the south. The other variations of this type concern the connexion between the shaft and the chamber. The passage is always long, from 1 to over 2 m. in length, and it opens in the north wall of the chamber flush with the east wall or near it. The shaft itself is a 2-m. opening partly in rock and partly cased through the mastaba with masonry like that of the retaining wall of the mastaba. The opening of the passage in the shaft is less than the 2-m. side of the shaft in which it opens. By this fact a 'false door-jamb' is formed on the western side of the passage between the shaft and the chamber. This characteristic is marked in types 4 and 5 by the figure (1) in parentheses. In a few cases a shallow 'false jamb' is formed also on the eastern side of the passage, and this feature when it occurs in types 4 and 5 is marked by (4). But for type 1, these rare forms are very minor variations of the main form. More characteristic is the height of the opening of the passage in the north wall of the chamber. This height I mark by letters as follows:

r: opening at roof-level with a deep drop from floor of passage to floor of chamber (Fig. 32).

m: opening at or near middle of chamber wall, with rise to roof and a drop to floor of chamber (Figs. 33, 34).

l: opening low down in north wall with a small step down from floor of passage to floor of chamber, and a high rise to roof of chamber (Fig. 36).

f.: opening at floor-level of chamber with north wall extending upwards above opening (Fig. 35).

In addition to these variations the passage may be horizontal from shaft to chamber or it may slope

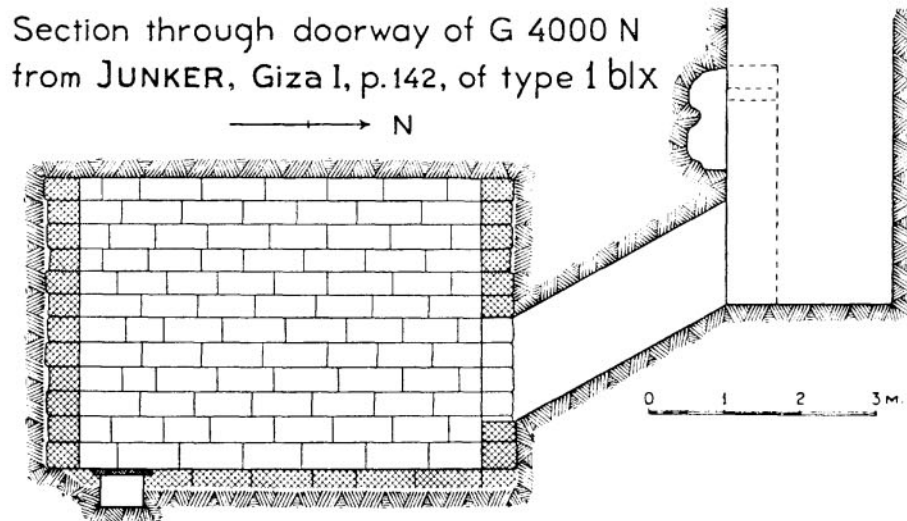
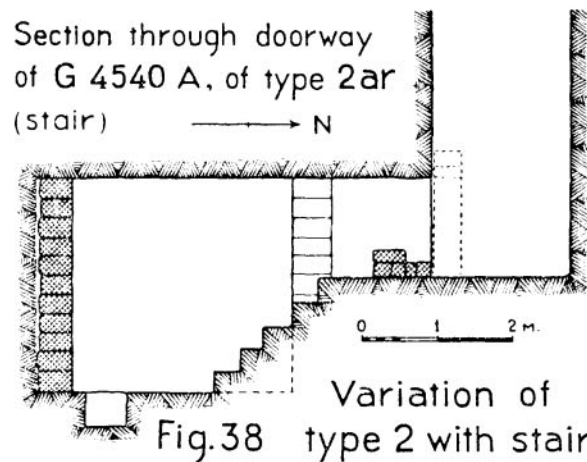
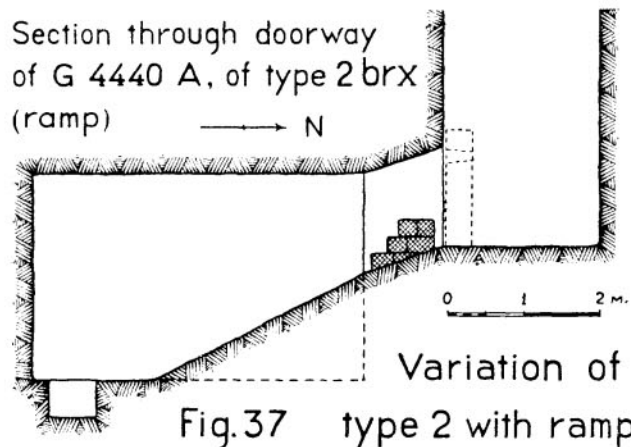

Fig. 36



downwards. The floor of the doorway on the shaft side may be at the level of the bottom of the shaft or above it. When the passage is horizontal the type is designated as 1 ar, 1 am, &c. When the passage slopes down to the opening in the chamber, an 'x' is added to the type designation (type 1 arx, &c.). The designation 'x' combined with any type marks the connecting passage as sloping in some degree (Fig. 36).

(2) Variations of Shaft Type 2

Type 2 is also a lined-chamber type, and resembles type 1 with the passage opening at or near roof-level (2 ar, 2 br, or 2 cr). Its chief feature is a rock-cut ramp or stair inside the chamber connecting the floor of the passage with the floor of the chamber (Figs. 37, 38). This type by its nature does not present all the variations of type 1. Usually the opening is high up, but a few examples occur with the opening in the middle of the north wall of the chamber. Although type 2 usually has a lined chamber, a few cases, being unfinished, were left unlined.

(3) *Variations of Shaft Type 3*

Type 3 represents the unlined form of type 1. The large high unlined chamber on the south of the shaft shows the same variations as type 1 (3 ar, 3 am, 3 al, 3 af, 3 br, &c.), with the sloping passage indicated by 'x' appended to the type designation.

(4) *Variations of Shaft Type 4*

Type 4 is a poorer form of type 3, in which the chief feature is that the height of the chamber is about the same height as the passage. If there is any difference in the two measurements it is equalized by a step down from the floor of the passage to the floor of the chamber. Thus the significance of the height of the opening in the north wall of the chamber automatically ceases. The variations in the

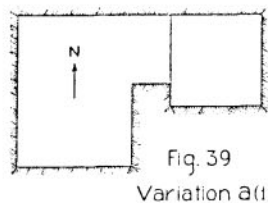

Fig. 39
Variation a(1)

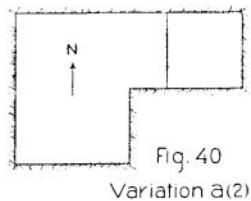

Fig. 40
Variation a(2)

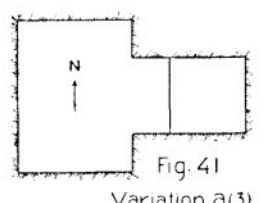

Fig. 41
Variation a(3)

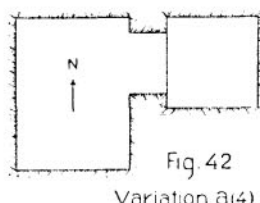

Fig. 42
Variation a(4)

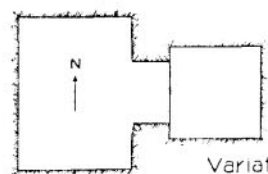

Fig. 43
Variation a(5)

form of the chamber and of the connecting passage present certain modifications of the older forms of types 1-3. These variations persist through type 5, and although all the variations of type 5 do not appear in the examples of type 4, the type designations are outlined for both types (see type 5, below):

Type 4 a (1): with 'false door-jamb', as type 1 a; see Fig. 39.

Type 4 a (2): the doorway being of the same width as the shaft, the passage shows no 'false door-jamb'; see Fig. 40.

Type 4 a (3): the doorway as type 4 a (2) opens in or near the middle of the chamber; see Fig. 41.

Type 4 a (4): with opening near one end of chamber has two 'false door-jamb's, one on each side of the doorway; see Fig. 42.

Type 4 a (5): like 4 a (4), with opening in or near middle of

chamber; see Fig. 43.

Type 4 b: has the same variations as type 4 a.

(5) *Variations of Shaft Type 5*

Types 3 and 4 represent two forms of the same type, one an unlined form of the old type 1 with a high chamber, and the other a cheapened modification of the better type 3. Type 5 represents a further cheapening of both types 3 and 4. The difference is based on the length of the connecting passage and fixed arbitrarily at a passage length of 0.5 m. When the passage is over 0.5 m. long from shaft to chamber, the type is marked as 3 or 4. When the passage is 0.5 m. or less in length, the type is thereby fixed as type 5. The connecting passage of type 5 is sometimes less in length than 0.1 m., and appears to present two narrow door-jamb's one on each side.

The main variations are 'a' and 'b' as for the preceding types. Usually the passage enters the chamber at roof-level as in type 4, but a few examples have the roof of the chamber higher than the roof of the passage and so resemble type 3. The examples present the same variations as type 4, showing a gradual modification of the old form of types 1-3. As in type 4, these variations are marked with figures in parentheses, as follows:

Type 5 a (1): with false door-jamb on one side of doorway; see Fig. 39.

Type 5 a (2): without false door-jamb; passage same width as shaft; see Fig. 40.

Type 5 a (3): without door-jamb; with opening near middle of chamber; see Fig. 41.

Type 5 a (4): with two door-jambs, one on each side of doorway; opening near one end of chamber; see Fig. 42.

Type 5 a (5): with two door-jambs; opening at or near middle of the chamber; see Fig. 43.

Type 5 b (1) to (5): variations corresponding to those marked by a (1) to (5).

The chambers of type 5 are characterized by differences from types 3 and 4 which cheapen the cost of excavation. The connecting passage is short and requires less labour in cutting. The chambers are usually low, much lower than those of type 3, and are generally cut from the roof downwards. But the chambers themselves vary greatly in area from chambers of over 10.0 sq. m. to some less than 1.0 sq. m. in area. The cost of cutting decreased with the size of the chamber, and it has seemed to me important to separate the large chambers of type 5 from the small chambers. I have therefore made a comparison of the sizes of over five hundred chambers and marked an area of 2.0 sq. m. as a practical line between large chambers and small chambers according to the practice of the tomb-makers at Giza. Those chambers above 2.0 sq. m. in area I have marked as large chambers and those of less than 2.0 sq. m. as small chambers. The smaller chambers bear the designation 'c', which in types 1-3 marked the large square chamber. Thus the variations of type are increased by type 5 c as follows:

Type 5 c (1): like type 5 a (1), with floor area of less than 2.0 sq. m.

Type 5 c (2): like 5 a (2); area, less than 2.0 sq. m.

Type 5 c (3): like 5 a (3); area, less than 2.0 sq. m.

Type 5 c (4): like 5 a (4); area, less than 2.0 sq. m.

Type 5 c (5): like 5 a (5); area, less than 2.0 sq. m.

By the introduction of type 5 c, the large and the small chambers of type 5 are made visible at the first glance by the type designation.

Finally, a number of examples of type 5 represent a small squarish variation in which the area of the chamber was about the same as that of the shaft. As these seem to be very late in date and perhaps derived from the form of some of the late-built shafts and chambers of type 8, I have deemed it desirable to mark these examples as type 5 d. The examples fall into two chief variations:

Type 5 d (1): with 'false door-jamb' on one side of doorway resembling in effect type 5 a (1).

Type 5 d (2): with door-jamb on each side of doorway; resembling type 5 c (5).

(6) *The Variations of Shaft Type 6*

Shaft type 6 has no connecting passage or door-jambs. The chamber opens directly into the shaft. The type is most numerous in Dyns. V-VI, and this fact might be taken as evidence that type 6 was a late type developed from type 5. But in many of the smaller stairway tombs of Dyn. III the chamber opened directly into the end of the stairway. Furthermore, many shafts of the reign of Sneferuw have no door-jambs or connecting passage. Thus it must be admitted that type 6 is an old form, and as a matter of fact one example at least occurs in the annex to mastaba G 1233 of the nucleus cemetery G 1200, and is clearly not later than the reign of Chephren. Type 6 was not used generally for large shafts with large chambers until Dyn. V. The increasing poverty of the community using the Giza Necropolis in Dyns. V-VI is emphasized by the frequent use of the type 6 in the medium-sized and small burial-chambers of that period. The majority of the chambers have an area less than 2 sq. m., and a large number have areas less than 1 sq. m. The chambers with larger areas present the two variations 'a' and 'b' used for types 1-5. The 'a' variation, with chamber parallel to the adjoining side of the shaft, never presents the minor variations numbered a (1) to a (5) in the earlier types.

Nevertheless, it has a form which was obviously derived from type 5 a (2) by the omission of the door-jambs and another variation corresponding to type 5 a (3) with opening in the middle of the chamber. These two variations are therefore used for type 6 a, as follows:

Type 6 a (2): with long chamber parallel to the adjoining side of the shaft; opening flush with one end of the chamber (usually the east or north end) (Fig. 44).

Type 6 a (3): long chamber parallel to adjoining side of shaft; opening in or near middle of chamber (not flush with end) (Fig. 45).

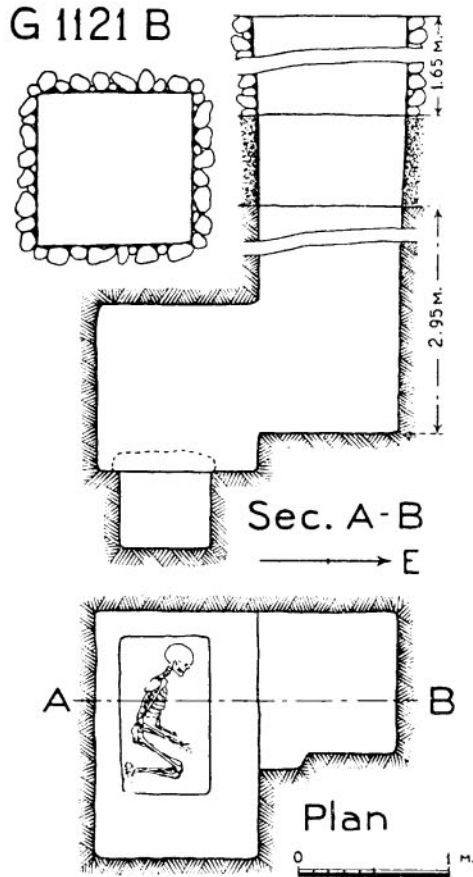

Fig.44 Shaft type 6a(2)

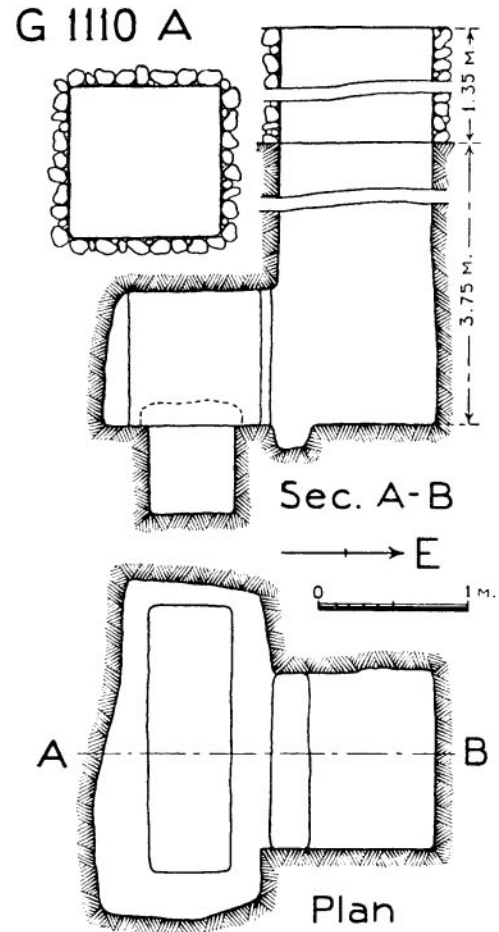

Fig.45 Shaft type 6a(3)

The variation 'b', by the omission of the passage or jambs, loses all the distinguishing marks of the subdivisions of this letter in the old types, and its new characteristics are marked as follows:

Type 6 b (1): the long chamber runs out corridor-like from the side of shaft, with its long walls parallel or contracting slightly inwards (Fig. 46).

Type 6 b (2): the long chamber has a very characteristic widening towards the inward end which is 'fan-shaped' in appearance; the 'fan-shaped' chamber appears in sporadic examples in type 5 b, but becomes marked in frequency in type 6 b (Fig. 47).

Type 6 b (3): has a chamber of irregular form.

Type 6 b degenerates into a short recess chamber often nearly square in form. For this I have taken the variation letter 'c' (cf. type 1):

Type 6 c (1): recess chamber with parallel sides (Fig. 48).

Type 6 c (2): 'fan-shaped' recess chamber (Fig. 49).

Type 6 c (3): irregularly cut chamber (often unfinished).

The recess chamber (variation 'c') takes on in some cases so shallow a form that the burial (csk or tcsk) cannot be contained within the chamber. The part of the burial in the shaft is protected by an extension constructed of c.b. or rough masonry and roofed with leaning slabs or less often with horizontal slabs:

Type 6 d: recess chambers of meagre depth with body partly in recess and partly in shaft; protected by built extension in shaft; when found open and empty, recesses of depth less than 0.4 m. are reckoned as of type 6 d (Fig. 50).

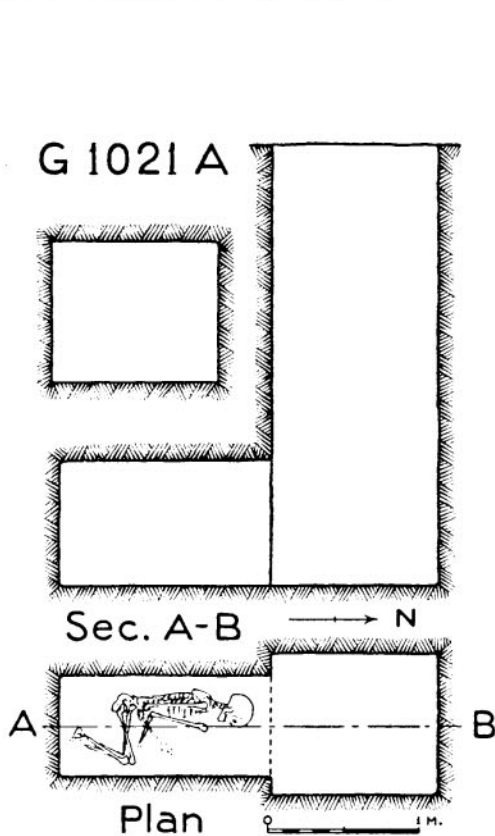

Fig. 46 Shaft type 6b(1)

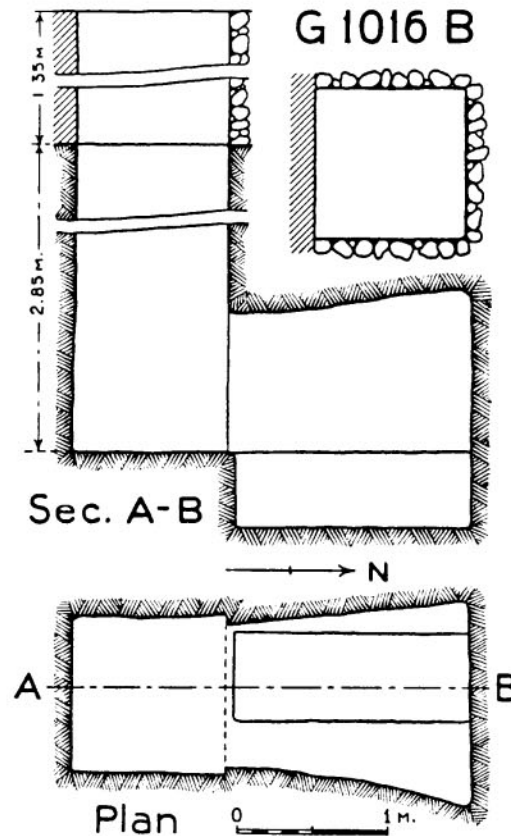

Fig. 47 Shaft type 6b(2)

(7) Variations of Type 7

Shaft type 7 is an open-pit shaft with the burial in the bottom of the shaft or in a chamber constructed in the shaft. In a few cases a chamber is sunk in the rock, but in most cases the chamber is built of rubble, masonry, or c.b.

The variations of type 7 are based on the position and roofing of the chamber, as follows:

Type 7 a: chamber in middle of shaft:

7 a (1): with flat roof of stone slabs bound with mud or gypsum plaster (Fig. 51 a).

7 a (2): with chamber sunk in rock; flat roof of slabs bound with mud or plaster (Fig. 51 b).

7 a (3): like 7 a (1) but with roof of corbelled slabs (Fig. 52).

7 a (4): like 7 a (1) but with c.b. pent roof or rudely vaulted roof, plastered with mud.

7 a (5): like 7 a (1) but roofed with leaning-course c.b. vault.

Type 7 b: with chamber on east or west side of shaft, formed by one wall built of rubble, masonry, or c.b.:

7 b (1): roofed with flat slabs, wedged against side of shaft, bound with mud or plaster (Fig. 53).

7 b (2): as 7 b (1) but with roof of leaning slabs resting against side of shaft (Fig. 54).

7 b (3): with rubble and mud roof of obscure construction.

7 b (4): with chamber on side, but without the roof being preserved; sometimes sunk in rock.

Type 7 c: open-pit grave with body, sometimes in a wooden box, covered with filling of shaft; no subdivisions.

Type 7 d: designation not assigned.

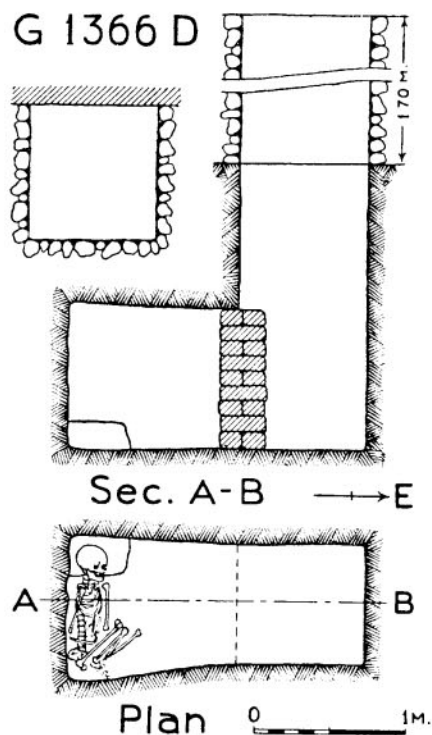

Fig. 48 Shaft type 6c(1)

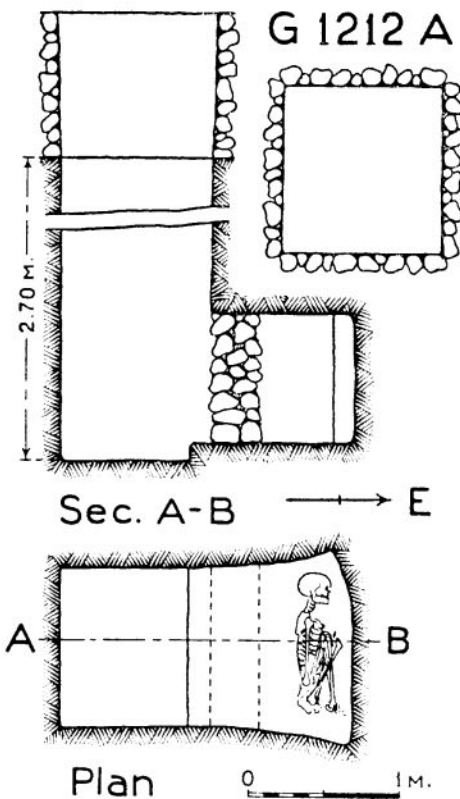

Fig. 49 Shaft type 6c(2)

Type 7 e: smaller shaft and chamber built in open shaft (see *Naga-ed-Dér*, III, p. 22).

Type 7 x: empty open shaft with no chamber preserved, but possibly originally of type 7 a-e.

The shafts of type 7 become frequent in the subsidiary shafts of Dyn. V, and increase in frequency in the small mastabas of Dyn. VI.

(8) *The Variations of Shaft Type 8*

The shaft type 8 presents a form in which the shaft and the chamber were constructed either in the filling of a mastaba or intruded in the sand-filled corridors and chapels of the older cemetery. The chamber was constructed of masonry, c.b., or rubble, and roofed with stone slabs often taken from older mastabas (in particular monolithic stelae). The shaft was also built of the same materials but more frequently of masonry.

The walls of the older constructions in which these built shafts were intruded were utilized to save cost. The variations of type 8 repeat the variations 'a' and 'b' of the rock-cut chambers and are as follows:

Type 8 a: with chamber parallel to the adjoining side of the shaft as type 5 a; variations a (1) to a (5) as 5 a (1) to 5 a (5) (Figs. 55, 56).

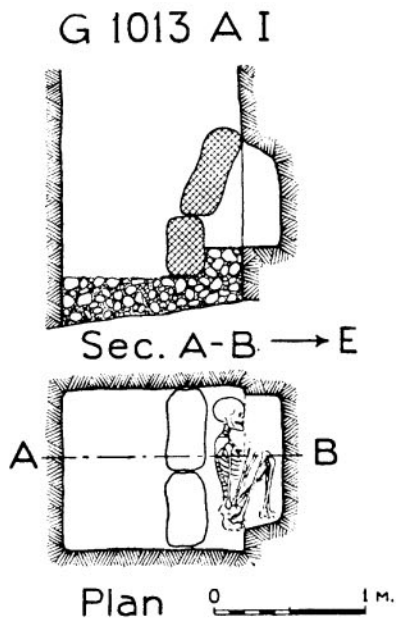

Fig.50 Shaft type 6d.

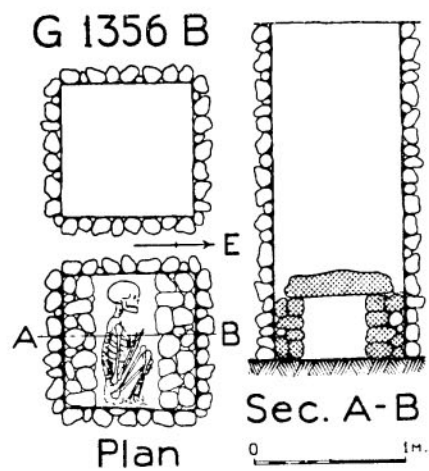

Fig.51a Shaft type 7a(1)

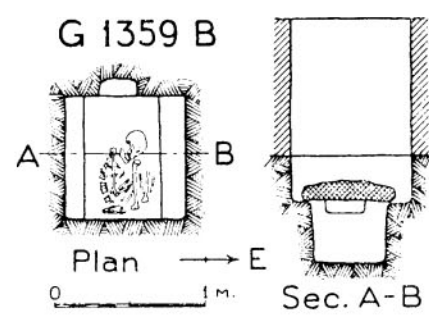

Fig.51b Shaft type 7a(2)

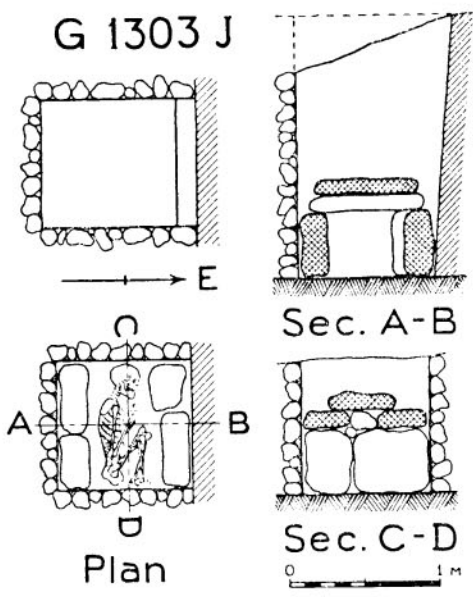

Fig.52 Shaft type 7a(3)

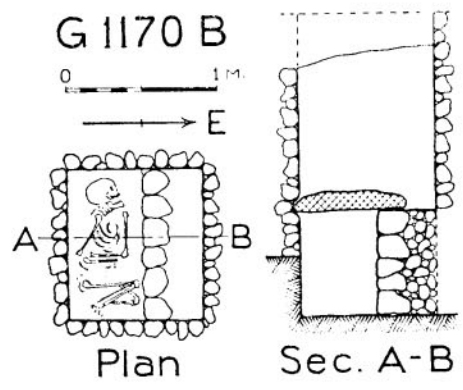

Fig.53 Shaft type 7b(1)

Type 8 b: with chamber at right angles to adjoining side of shaft:

8 b (1): with one door-jamb as 5 b (1) (Fig. 57).

8 b (2): without door-jamb as type 6 b (1); the most numerous class (Fig. 58).

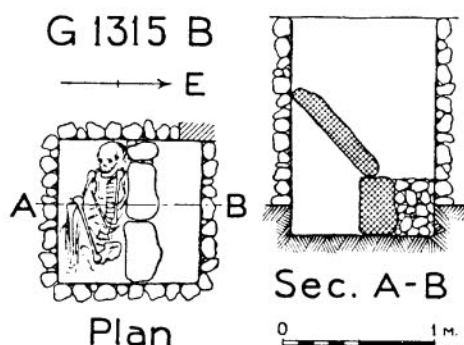

Fig. 54 Shaft type 7 b(2)

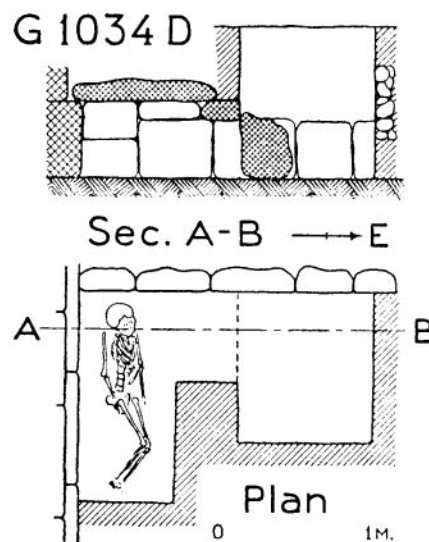

Fig. 55 Shaft type 8 a(1)

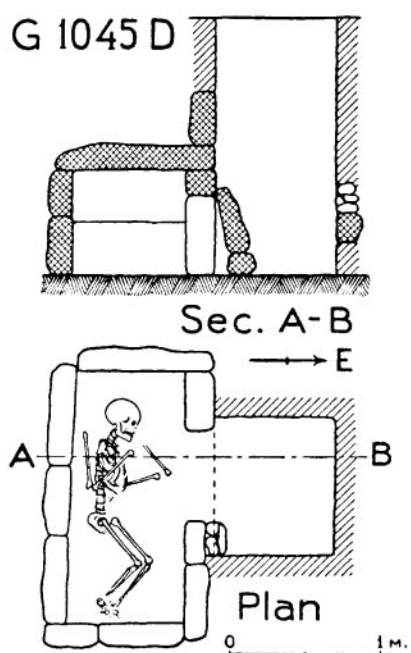

Fig. 56 Shaft type 8 a(5)

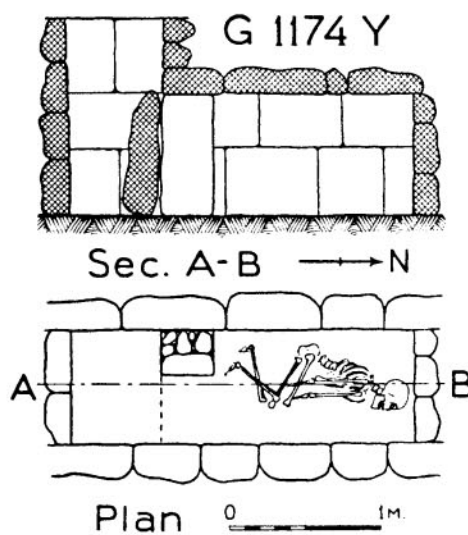

Fig. 57 Shaft type 8 b(1)

8 b (3): like 8 b (1) but roofed with leaning-course c.b. vault.

8 b (4): chamber opening in corner of shaft.

Type 8 c: imitation of type 6 c:

8 c (1): like 6 c (1); 8 c (2) like 6 c (2).

Type 8 d: imitation of 6 d.

Type 8 e: chamber as 6 c, sunk in rock and roofed with slabs.

Type 8 f: abnormal variation of type 8 b in which the whole of the shaft was built over one end of the roof of the built chamber.

Type 8 is the predominating type of the intrusive shafts of the latest period, which were made after the sanding-up of the cemeteries.

(9) *Variations of Shaft Type 9*

Shaft type 9 presents a development which was frequently used in the large mastabas of Dyns. V and VI. A large N-S chamber was approached by a sloping passage cut in the rock descending from the north or east, usually from outside the exterior wall of the mastaba, but occasionally from the floor of the chapel. In many cases a built passage was constructed in the rock-cut passage and roofed with slabs with the empty space above the roof packed with rubble and mud. The passage was blocked with plug-stones like the pyramid passages of Dyns. IV-VI. The type appears to have been derived from the pyramid type of passage rather than the older type of sloping-passage tomb. The variations are as follows:

Type 9 a: N-S chamber, entered from the east near the north end of the east wall of the chamber:

9 a (1): with rock-cut passage.

9 a (2): with built passage in the rock-cut passage.

Type 9 b: with N-S chamber entered by sloping passage from the north or south; entering the chamber through the east side of the north or south wall of the chamber:

9 b (1): with plain rock-cut passage.

9 b (2): with built passage in the rock-cut passage.

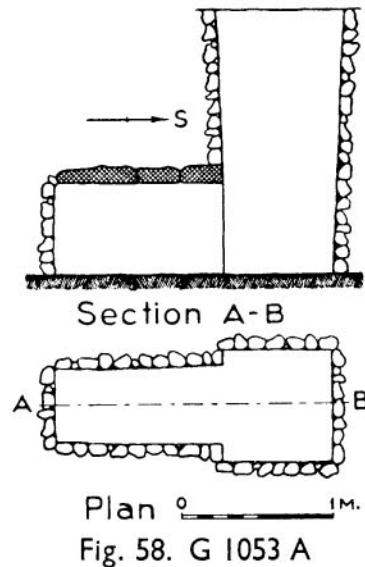

(10) *Summary of the Square Shafts with Rock-cut Chambers: Types 1-6*

The six types of square shafts with rock-cut chambers include all the important burial-places in the Giza Necropolis except those of the later type 9. The six types fall into two groups, types 1-5 with connecting passage or door-jambes between shaft and chamber, and type 6, with chamber opening directly into the shaft. Both these features are to be noted in the older burial-places of Dyn. III and the reign of Sneferuw. The direct opening was even in the older burial-places a cheaper type. At Giza, however, the development begins afresh with the lined chamber of type 1, used in fourteen of the fifteen initial mastabas of the Cheops cemetery. The similar type 2 with the ramp or stair inside the chamber appears later than type 1 in Cem. G 4000. Type 3 appears first in the chambers of the eastern nucleus cemetery, dated by me to the end of the reign of Cheops. It also appears in Cem. G 4000 later than type 2. In the annexes to G 1223 and G 1225, type 3 appears subsidiary to chambers of type 1. In fact, type 3 is the same as an unlined type 1. Wherever chambers of types 3 and 4 come into proximity, the examples of type 4 are later by position than those of type 3, and it is obvious that type 4 is only a cheaper form of type 3.

The mastabas of the four nucleus cemeteries, G 1200, G 2100, G 4000, and G 7000, were originally all one-shaft mastabas with one square 2-m. shaft. These belonged to the most important persons buried in the necropolis, other than the kings themselves and their queens. It was for these great persons that the lined chamber of shaft type 1 was designed, and from that type the other types were developed locally practically independent of the older forms used in previous reigns. As time went on, the size of the square shaft diminished and with every decrease in the size of the shaft the labour of cutting was lessened. The shafts gradually decreased to about 1.0 × 1.0 m. and the vast majority of the

shafts of Dyns. V and VI are of the smaller sizes. Old shafts of the 2-m. size, which were used later in Dyn. V, were often not excavated in rock to the full size but continued downwards of much less size. Again, the depth of the shaft in rock was a weighty factor in the cost of excavation, and in this the tendency favoured more shallow shafts. The increase in the use of the smaller and less elaborate chambers followed the same tendency towards less expensive shafts even for the great men of Dyns. V and VI.

The shafts 4-6 result from the general tendency towards economy in preparation. Aside from this, attention must be directed to the general methods of rock-excitation and the differences in the cost of shafts types 1-3. The method of excavation of rock-shafts is revealed by a large number of examples

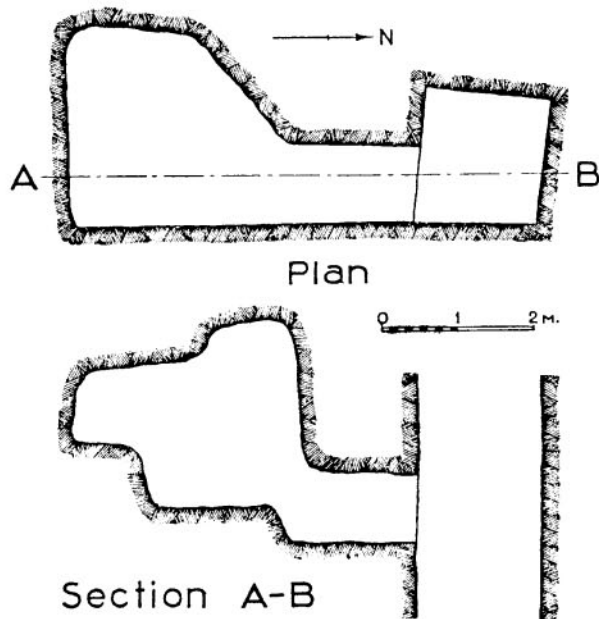

Fig. 59. G 7750 B (I)

which were not completely finished. The outline of the mouth of the shaft was marked out on the surface by a rectangular trench varying in depth from 0.15 to about 0.3 m., cut apparently with the hardened copper chisel. The resulting block of stone was trenched, dividing it into ridges. These ridges were then smashed with heavy hard-stone hammers, of which many were found in the debris. The bottom of the shaft as thus begun was roughly dressed, probably by pounding with hammers, and the trenching operation was continued until the desired depth had been obtained. Finally, the vertical sides of the shaft were dressed more or less flat (according to the size and quality of the shaft). The excavation of the shaft was one of the easier methods of excavation, entirely carried out *with downward blows of chisel and hammer*. The cutting of passage or doorway laterally in one side of the shaft was carried out in a similar manner

by cutting vertical grooves (not so deep as the trenches) and breaking away the intervening ridges, which was no great labour to the Egyptian craftsmen. The position of the chamber with relation to this passage made, on the contrary, a great difference in the cost of cutting chambers of the same size and height. When the passage was designed to enter the chamber at roof-level, the lateral cutting was continued until the roof was brought into existence and then the chamber was excavated downwards from the roof to the floor. This method required again only downward blows of the tools employed, and the trench and hammer operation could be used. When the passage entered the chamber at floor-level and the projected chamber roof was high above the roof of the passage, the labour of cutting was more difficult. The evidence of the process is contained in the unfinished chambers of G 7750 B (see Fig. 59). Owing to the great difficulty of cutting upwards with upward blows of the tools and the continual dribble of dust and spills into the face of the workman, a vertical shaft about a metre square was cut from the roof of the passage upwards to the roof of the chamber. The chamber was then excavated laterally from this vertical cutting. The amount of labour in the upward cutting varied with the height of the opening of the chamber, increasing as the opening decreased in height above the floor of the chamber. The chisel and adze marks on the walls of the chamber show that the dressing of the walls of the chamber was carried out with downward strokes, as was naturally to be expected. In some of the best examples, the walls have been further smoothed down by rubbing, probably with a flat slab, perhaps of harder stone.

The method of cutting chambers is confirmed by several facts. The cheaper types of chambers

(types 4, 5, and 6) were generally cut in laterally with the roof of the passage at the level of the chamber roof, and when the chamber was higher than the passage the difference was equalized by a step from floor of passage to floor of chamber (made by downward excavation). Another bit of confirmatory evidence is given by a few examples, types 1-3, in which the passage was cut in with its roof on the level of the chamber roof, and after the excavation of the chamber had its upper part built in with masonry to create the high chamber form of types 1 af, 1 bf, or similar. A few examples of high chamber types had a 'window', cut laterally from shaft to roof of chamber, which gave access at roof-level and permitted the excavation downwards of the whole chamber.

b. The Occurrence of Stone-lined Chambers at Giza

The stone-lined chamber, the origin of which is so clearly revealed by the Medum tombs, is characteristic of the mastabas which by position and type appear to be the earlier. These include all of the ten mastabas in Cem. G 1200, all of core-type II a. The burial-shafts (one in each mastaba) are: 1 of type 1 ar (G 1227); 2 of type 1 al (G 1201 and G 1207); 1 of type 1 alx (G 1233); 1 of type 1 al (G 1235); 1 of type 1 brx (G 1223); 1 of type 1 bl (G 1225); and 3 of type 1 cl (G 1203, G 1205, G 1209). An examination of the type variations used for the owners as revealed by the slab-stela proves that the type variations, 1 a, 1 b, and 1 c, were not adopted to accord with the sex or rank of the owners. These variations appear to be purely arbitrary. In Cem. G 2100, in which one mastaba is of type II b (G 2130) and all the rest of type II a, five of ten chambers are lined and are:

- 2 of type 1 al (G 2120, 2130).
- 2 of type 1 cm (G 2100, G 2135).
- 1 of type 1 bf (G 2210).

In Cem. G 4000 the chambers of the rows 4-6 and lines 1-7 are lined, with these exceptions: G 4650, 4240, 4740, 4750, and 4760. The mastabas are of core-types II b (5 mastabas), III i (2 mastabas), and IV i (15 mastabas). The shaft types are as follows:

- 4 of type 1 ar; G 4260, 4360, 4150, 4250.
- 1 of type 1 am; G 4460.
- 1 of type 1 al; G 4560.

Total shafts of type 1 a, 6 shafts.

- 1 of type 1 br; G 4160
- 1 of type 1 blx; G 4000 N.
- 3 of type 1 cm; G 4350, 4450, 4550.
- 1 of type 1 cl; G 4660.

Total shafts of type 1, 12 shafts.

- 1 of type 2 ar (stair); G 4540.
- 2 of type 2 br (stair); G 4750, 4640.
- 2 of type 2 brx (ramp); G 4140, 4440.
- 1 of type 2 bm (stair); G 4240.
- 1 of type 2 cr (ramp); G 4340.
- 2 of type 2 cr (stair); G 4740, 4760.

Total shafts of type 2, 9 shafts, of which 4 are unlined (G 4240, 4740, 4750, and 4760).

The sum total of shafts of types 1-2 with lined chambers is seventeen, which are contained in seventeen mastabas. The lined chambers form a nearly solid block in Cem. G 4000. The thirty-two lined

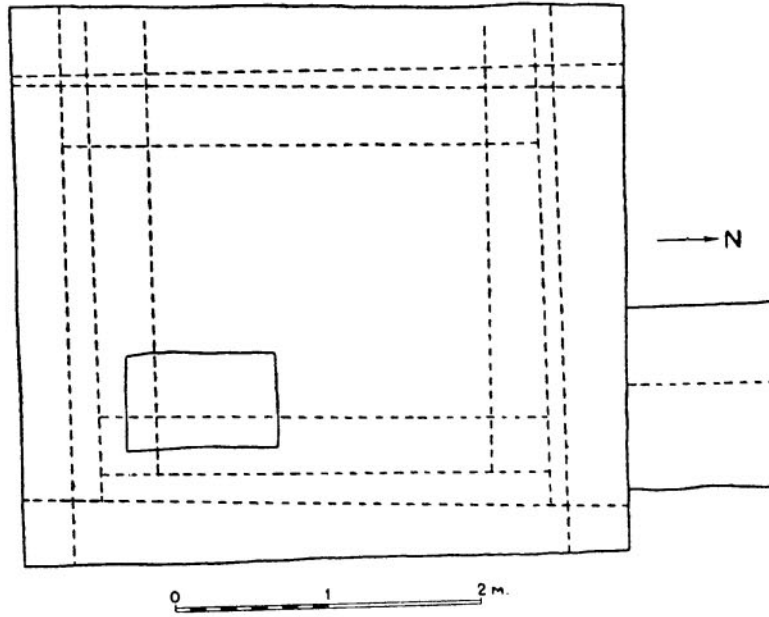

Fig. 60. G 1225 A

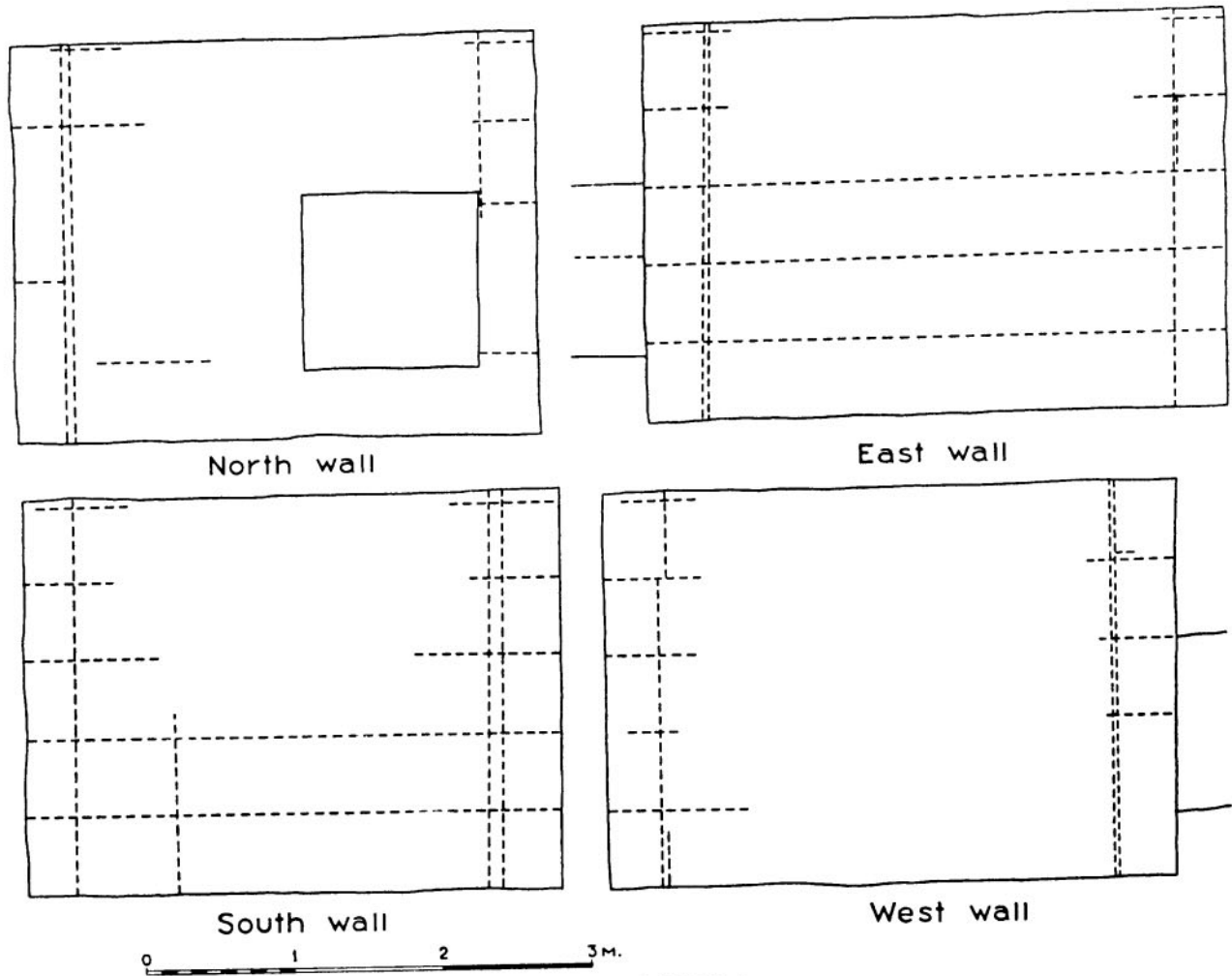

Fig. 61. G 1225 A

chambers of the Western Field include all the early mastabas of that field. They are all one-shaft mastabas, which is another indication of their early date, except G 4000, which belongs to the class of tombs in which the wife, because of her rank, takes a position of unusual prominence. The group of lined chambers presents certain variations of the shaft types which are of considerable interest.

Thus in the Western Field, in the early mastabas, thirty-two chambers of types 1 and 2 were lined and six chambers of type 2 (including G 2000) were designed for linings but left unfinished. Thereafter the lining of chambers ceased to be generally practised at Giza. In the Eastern Field, only one chamber was found with finished lining (G 7510) but without a pavement. Two other chambers had unfinished linings, G 7130 B (south wall of coffin-chamber) and 7430 B (main chamber lined to a certain height). All the other chambers in the Eastern Field as well as all later chambers in the Western Field and G I S were not lined. It is clear that the general use of lined chambers in mastaba-shafts ceased at

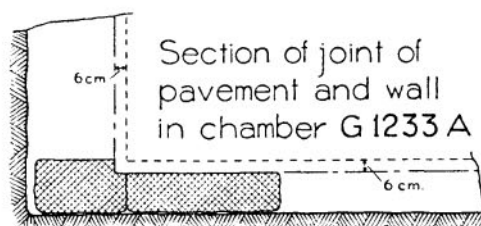

Fig. 62 0 1 m.

Giza about the end of the reign of Cheops, but occurs in isolated examples in the reign of Chephren. At other sites, sporadic examples occur in very large mastabas of Dyns. V-VI.

In comparison with the occurrence of lined chambers in mastaba-shafts at Giza, it is to be remarked that the three small pyramids G I-a, b, and c had burial-chambers lined with white limestone. The small pyramid south of the Second Pyramid had not been lined (see Hölscher, *Chephren*, p. 67), although the burial was dated by a sealing to the reign of Chephren. At the Third Pyramid only G III-b had a lined chamber, while G III-a, the most important of the three pyramids, had a plain rock-cut chamber. The pyramid G III-c had an unfinished chamber. The royal pyramids of Dyns. V-VI had generally a built or a lined burial-chamber.

The lining of the chambers consists of smoothly dressed white limestone with fine joints both horizontally and vertically and with courses carefully bonded. The entrance passage was usually uncased, but entered the lining of the chamber in a finely dressed opening. This opening was roofed with a single long slab, part of the lining of the north wall. The floor was paved with fine white blocks also, a feature that was only omitted in some of the later examples. The canopic pit in the SE corner was cut through the pavement and usually entered the rock below the pavement. The construction of this lining was marked out by an arrangement of red lines on the roof and the walls of the chamber (see Figs. 60, 61). The construction of the lining began with the lining of the walls on all four sides. Each block was dressed on the bottom and two ends for setting. The top of the block was dressed flat, apparently after the setting of the whole course to which it belonged. When the wall was completed the whole surface appeared only roughly dressed. At this point the pavement was laid, being also finely fitted to the lowest course of the side walls and internally. After the construction of the whole the final dressing took place and, in this process, the dressed wall often fell a centimetre or two inside the face of the lowest course against which the pavement was built. The pavement was also dressed down so that its upper surface fell below the top of the first course of the side walls (see Fig. 62).