

- (c) The 3-ell mark was taken as the starting point for the levelling and was carried across the corridor and along both walls to the court and from there throughout the temple. The triangles of the 3-ell line were the only ones found filled in solid with red.
- (d) Having fixed the 3-ell mark at each convenient point, the other ell marks at that point were fixed by dead measurement up and down.
- (e) The instruments used in the levelling were:
- (1) A stout cord, perhaps the same cord used in linear measurements on building sites and fields.¹
 - (2) A wooden isosceles triangle, with a hole in the middle of the odd side for attaching a plummet string.
 - (3) A plumb-bob on a string.
 - (4) Possibly a long straight-edge of wood to which one or more triangles may have been attached; it would also have been possible to have the triangles marked on the side of a broad straight-edge.
- (f) The cord was stretched horizontally along the wall, with one end on the 3-ell mark, and levelled by holding the base of the wooden triangle, odd side up, along the cord so that the string of the plumb-bob bisected the pendent angle between the equal sides, perhaps marked with a straight vertical line; the accuracy of the operation would be proportional to the size of the wooden triangle and would have been greatly increased by the use of the straight-edge mentioned above.
- (g) When the cord was adjusted and stretched very taut, a red line nearly one centimeter thick was drawn along the cord; in some cases, in the Giza mastabas, the splashing of the red paint indicates that the cord was smeared with red paint and snapped against the wall.

In addition to the levelling lines, the ell marks, and the triangles, every stone appears to have borne an inscription in red paint, repeated, on both long sides. These were near the top of the stone and between two of the levelling lines, but not necessarily connected with them. We found it difficult to determine whether the inscriptions or the levelling lines were made first. The inscriptions were for the greater part concealed behind the brick casing and were recovered in 1923 by cutting away the casing. They are given in Pl. XI carefully copied by Mr. Alan Rowe. The list is as follows:

- (1) Wall between rooms (13) and (24), second course, first stone on west, western end of stone:
 - i. On face in room (13).
 - ii. On face in room (24).

ꜥprw Mnkꜣwrꜥ-thw wꜣꜥt sꜣ.
Distinguishing mark, antelope.
- (2) Same wall between rooms (13) and (24) second course second stone from west, eastern end of stone:
 - iii. On face in room (13).
 - iv. On face in room (24).

ꜥprw Mnkꜣwrꜥ-thw nꜥꜣs (?) sꜣ.
Distinguishing mark, *wꜥꜥ*.
- (3) Wall between rooms (13) and (15), first course, first stone on west, runs vertically about in middle:
 - v. On face in room (15).

ꜥprw Mnkꜣwrꜥ-thw nꜥꜣs sꜣ.
Distinguishing mark, *ꜣhw*-bird (? or *sꜣ*-bird).
- (4) Same wall between rooms (13) and (15) second course, third stone from west, east end:
 - vi. On face in room (13).

The only legible mark is *sꜣ*.
- (5) Wall between rooms (14) and (26), second course:
 - vii. On face in room (14).

ꜥprw Mnkꜣwrꜥ-thw nꜥꜣs sꜣ.
Distinguishing mark, not preserved.
- (6) Same wall between room (20) and room (36) and (37), second course, third stone from corner:
 - viii. On face in room (20).

ꜥprw Mnkꜣwrꜥ thw wꜣꜥt sꜣ.
Distinguishing mark, Jackal-with-feather, Cynopolis-nome.
- (7) Same wall between rooms (20) and (37 N), first course, second stone from corner:
 - ix. On face in room (20).
 - x. On face in (37 N).

ꜥprw Mnkꜣwrꜥ-thw wꜣꜥt sꜣ.
Distinguishing mark, *ꜣtp*.

¹ For the New Kingdom, see Borchardt, *Aeg. Zeit.* 42, p. 70. The object represented by the sign  *sꜣ*, may represent the same cord, taking the end loops as handles and the side loops as tags marking the ells. See the form of the sign in Dynasty I, Petrie, *R. T. I.* Pl. IX, 1-5; XI, 6, 16; XXI, 28; XXXI, 46.

- (8) Wall between rooms (16) and (20) and exterior, second course, second stone from corner:
 xi. On face in room (19).
ḥprw Mnkḥwrḥ-thw nḏś (?) sḥ.
 Distinguishing mark, *ḥhw*-bird (or Ibis).
- (9) Wall between rooms (27) and (22), second course:
 xii. On face in room (27).
ḥprw Mnkḥwrḥ-thw
 Distinguishing mark, not preserved.
- (10) Wall between rooms (10) and (37 S.), second course, third stone from corner.
 xiii. On face in (37 S.).
ḥprw Mnkḥwrḥ-thw wḥḏt sḥ.
 Distinguishing mark, *wḥḏ*
- (11) Great court, north of doorway (12), on west face near corner of pier:
 xiv. On face in court, facing east.
ḥprw Mnkḥwrḥ-thw nḏś sḥ.
 Distinguishing mark, a bird.

The signs which I have noted as distinguishing marks are usually after the inscription and of larger relative size than the signs in the inscriptions; but in two cases, the distinguishing mark was in front (Nos. vii and xii), in two cases underneath (Nos. ii and x), and in one case (No. xiii) both before and behind but not aligned with the inscription. A full list of these marks and a discussion of their meaning is given in Appendix E.

The levelling lines of the first course which appear to have been drawn first would have served primarily in levelling the top of that course and similarly the levelling lines of the second and third courses served the tops of those courses. In corridor (13), which had a sloping floor, special red lines were drawn to mark the tops of the sloping courses of the granite casing (see Pl. II). The line for the top of the first course had been almost entirely cut away in preparing the core wall for the casing, but the greater part of the line for the top of the second course was preserved. It began four centimeters under the western end of the 5-ell mark and sloped down to cross the 4-ell line 830 cm. from its western end, making a fall of 48.5 cm. in 830 cm. of length or one ell in 17 ells (895 cm.). The line sloped on downward toward the 3-ell mark, but ran behind the crude-brick casing, to reappear again on the core wall forming the side of the doorway (12). The vertical distance between the two lines was 90 cm., not an even ell, or two ells, like the levelling lines. It seemed clear that the levelling lines had been used to set the sloping course lines; and in the rest of the temple where the floors were flat, the levelling lines could also have been used to dress the tops of the courses of the casing. In rooms (7) and (8), where the casing was finished, the top of the courses did not coincide with the ell-lines, but special course-lines for the casing need not necessarily be assumed. See Appendix E.

(3) *Wall-Casings and Pillars*

The condition of the granite casing has already been described: 1, the finished but entirely destroyed red granite casing in rooms (7) and (8), 2, the unfinished but destroyed casing of black granite in the entrance corridor and the court, 3, the black granite block in place in the southern end of the portico, 4, the displaced black granite block in room (24), and 5, the unfinished black granite casing still in place on both sides of corridor (13). From the point of view of construction no distinction need be made between the red and the black granite. The evidence for the finished casing has long been known from the valley temple of Chephren.¹ The unfinished casing of the Mycerinus temple has now afforded important additional evidence of the method of construction.

First of all, the top of the foundation platform along the face of the core wall was dressed for each casing stone separately. The stone must, I think, have been dragged up and placed face down, probably on wooden beams, opposite the place it was to occupy in the wall. The stone had already been roughly dressed on the sides and front. On the front, a low ridge, 5–10 cm. wide and 3–5 cm. high, had been left on the four edges. While lying thus the bottom only of the first stone was dressed flat; the

¹ See especially Hoelscher, *Chephren*.

floor of the place to be occupied was dressed flat, and the crevices in the foundation platform chinked with limestone chips and white plaster. The core wall was also hollowed out to take the bulging undressed back of the stone; or, when the stone was a short one, the space was filled with a limestone slab, or rubble, set in the core wall with plaster. It was uncertain whether or not one side of the first casing stone was dressed before setting, but the second side was clearly seen not to have been dressed in the solitary block in room (7). The outer sides of the end stones in the three rows in corridor (13) were also undressed. There was no trace of a guiding line for the face of the finished casing to be found on the foundation platform; and it is probable that a stretched cord served this purpose.

The bottom of the stone and the place for it having been thus prepared, the next step is a matter of surmise. I would suggest that the granite block was then turned over on its lower edge as a fulcrum,

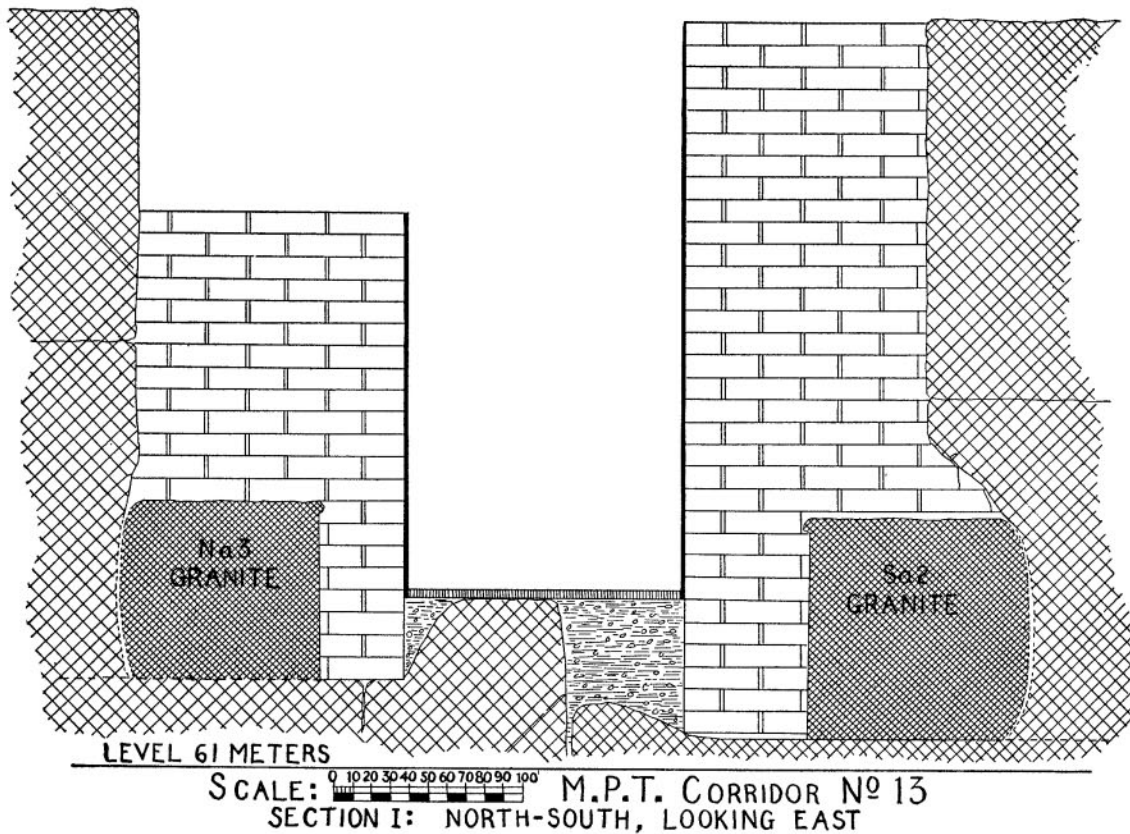
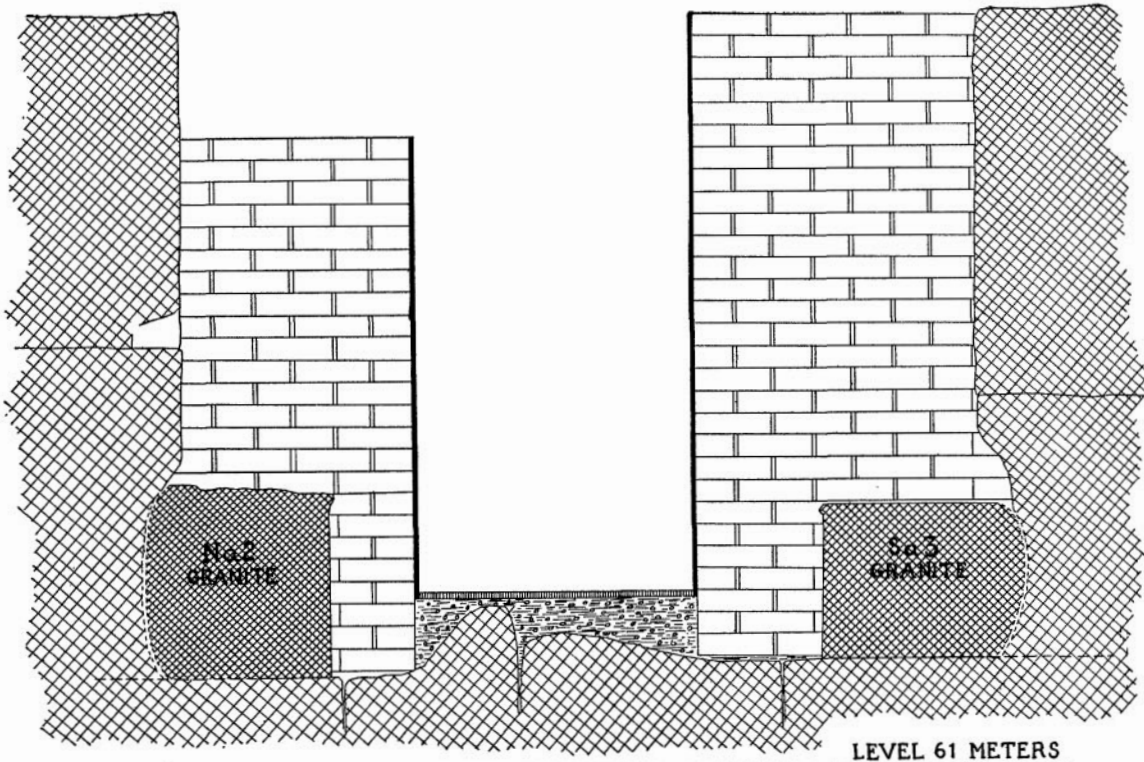

FIGURE 11

until it dropped into place in the wall, on a layer of plaster. The stones of the first course of the casing in the corridor were very irregular in size, but measured from 1.4 cubic meters to 1.8 cubic meters. Mr. W. P. Pollard of the Chemical Laboratory of the Egyptian Government has kindly ascertained for me that this stone weighs about 2,900 kilogrammes to the cubic meter. Thus the stones weighed from 4,060 to 5,220 kilogrammes each, or from 4 to 5.2 tons. As a matter of practical experience, we have, during the excavation of this temple, repeatedly turned over, partly with wooden levers and partly by hand, granite blocks of this weight with a gang of 10 to 12 men. I would point out that the ridges, especially that on the top edge, would greatly facilitate this process. In a few cases once the stone had dropped in place, it required little or no adjustment; but in many cases, two lever-holes were cut in the foundation platform under the front edge of the stone as it lay after dropping. These lever-holes measure about 20 cm. long by 12–20 cm. wide, and 5–8 cm. deep and usually lie under the face-line of the casing but sometimes entirely in front of that line. These holes prove that the final adjustment was made in these instances by levering with wooden beams. The layer of plaster of which we found abundant evidence in all emplacements, served to “float” the stone and facilitate the adjustment. It is well known that granite blocks “floated” in this manner can be shoved about by a few men even without levers; and it is to be presumed that some of the stones which were without lever-holes were so adjusted by hand.



SCALE:  M.P.T. CORRIDOR No 13
SECTION II: NORTH-SOUTH, LOOKING EAST

FIGURE 12



NORTH-SOUTH SECTION III
LOOKING EAST

SCALE:  M.P.T. CORRIDOR No 13
1:20

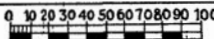
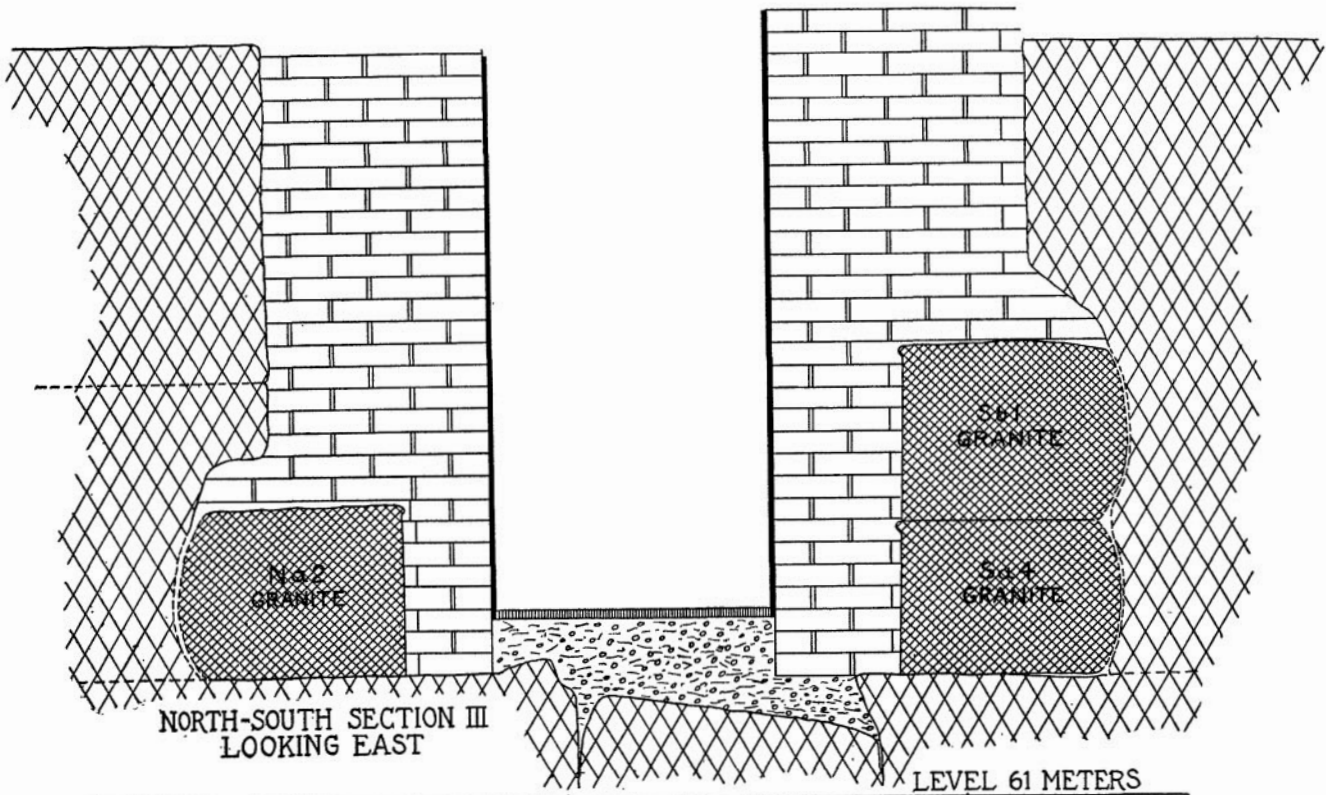
FIGURE 13

When the first stone was set, the side against which the next stone was to abut was dressed flat. The next stone was brought up, laid on its face on the wooden beams, and dressed flat both on the bottom and on the side which was to join the dressed side of the first stone. The emplacement for the second stone, having been prepared by dressing the floor and cutting out or filling in the core wall, was flooded with plaster; the second stone was then turned over and set in place against the dressed side of the first stone. This process was continued until the first course was finished.

The second course was laid in a similar manner, but without doubt from the top of a construction plane instead of from the top of the foundation platform. In room (13), while the work on the second course of the southern casing was in progress, the continuation of that on the first course of the opposite wall must have been hampered. That this was actually the case is shown by the fact that the fifth stone in the northern wall, stone (Na 5), was set in place with an interval of 135 cm. between it and the preceding stone (Na 4). The explanation seems to be that when the continuation of work on the first northern course was interrupted by the plane for the second southern course, the masons working on the northern wall discontinued and began again further east, beyond the end of the plane. For reasons which will immediately appear, I conclude that the plane used on the second course on the south approached from the west (the break in the wall which afterwards became doorway (25)), and that the second course was being built from west to east. It seems now an inexplicable piece of muddling to have begun the second course before the first was finished; but it is possible that Mycerinus died at this time and that during the last weeks of the construction, the work was disorganized.

The top of the first course was prepared for the second course one stone at a time. In room (13), the second course began in the middle of the wall, and three stones of the course were found in place. The top of course one west of the western stone of course two was still rough (undressed); but east of the eastern stone of course two, the top of course one had been dressed flat for a distance of 120 cm. The stone which was intended for this dressed place was certainly the unset stone which we found cast down on the bare limestone floor, against the core wall just east of the eastern stone of course one of this casing and covered by the crude-brick casing of Shepseskaf. This unset stone had a measured length of 119 cm. If the inclined plane had approached from the east, it would hardly have been possible to roll this unset stone off on the bare floor of the corridor so close to the casing already in place, but if it be assumed that the plane approached from the west, the position of the unset stone would be the one.

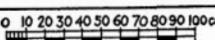
The most noticeable difference between the first and the second course lies in the absence of lever-holes for adjusting the stones of the second course. In working levers on top of a construction plane, it was of course easy to dig under the edge of the casing block and to use a fragment of hard stone as a fulcrum. One of the three stones of the second course shows the usual ridge around the edges of the face; another has this ridge and also two rough lever knobs on the lower edge; and the third has a flat face, which may however have been dressed after the stone was set. The stones of the second course, like those of the first, had been "floated" on plaster, and the close joints of both courses were filled with a film of plaster and pointed.

The faces of all these granite blocks, including the one abandoned before setting, bore inscriptions in red paint. In one place, the plaster used in setting course two had run down over the inscription on the stone below; in another, the writing was over the splash of plaster. But the presence of a similar inscription on the unset stone proves that these inscriptions were painted on the stone before setting, and where the inscription was written over the plaster, it had no doubt been rewritten after setting the stone. Probably the inscription, having been placed on more than one side of the stone, was rewritten horizontally on the face after the stone had been set; for some signs were found upside down on the face and the complete inscription was in several instances found on the undressed top or side.

The red inscriptions on the granite casing blocks consisted of four elements of which one, like the red inscriptions on the blocks of the core wall, was a "distinguishing mark." This distinguishing mark was not regularly placed with reference to the rest of the inscription, but was sometimes in front, sometimes behind, sometimes above or below, and was often repeated on the same face. As the stones were

dressed on the spot to fit the place, as the masons began in the middle of the wall in two cases, and as they began at several places simultaneously in the walls of the entrance corridor and the court, it is very doubtful to my mind whether these distinguishing marks could have served to indicate the place of the stone in the wall.¹ The first element in the inscription was the word *gš*. The four stones on the north wall of corridor (13) all bore the word *gš*, and as second element the word *imy-wrt*, but the two were separated by a space. The stones of the south wall in both courses had for the first element the word *gš*, and for the second the word *imn* (?), but on stones *S b 2*, *S a 4* and *S a 7*, the *gš* was separated by other signs from the word *imn* (?) while in *S b 3*, the word *imn* (?) was omitted or illegible. The third element was the same on all preserved inscriptions and read: *hmwt smyt*. The first interpretation which suggests itself is that the words *gš imy-wrt* and *gš imn* (?) designate the two sides of the corridor; but the *gš imy-wrt* side is the northern side and the other is the southern side, and I fail to see how the terms, both meaning "right-hand side," can apply. Furthermore what was the object in rewriting an inscription designating the place of the stone after the stone was in place? On the other hand, the word *gš* (det., house) "administration (?)," "estate," or something similar, has a meaning which may more probably belong to the word in our inscription; cf. the following titles:

- (a) *imy-rš gš* (det., house) "overseer of the *gš*."²
- (b) *imy-rš gš-imy-wrt š hr* (or *hr š*).³
- (c) *imy-rš gš* (det., house) *hryt-ntr* "overseer of the *gš* (det., house) of the necropolis."⁴
- (d) *hry-sštš n rš-š m gšwy* (det., house);
imy-rš š-t (pl.) *tš mh w m gšwy* (det., house).⁵

It seems therefore that *gš imy-wrt* and *gš imn* (?) may designate two different administrative departments, probably of the royal estates. The stones were marked after rough dressing and before setting perhaps to permit a control of the work to be credited to each and to save disputes as to which building gang the stones were assignable. If that supposition be correct, then the addition of *hmwt smyt* may be taken as a qualification of the other terms, that is the *gš-imy-wrt* of the *hmwt smyt* ("desert workshop"?) and the *gš-imn* (?) of the *hmwt smyt*.

The inscriptions have been carefully copied in fac-simile and repeatedly collated by Mr. Alan Rowe. His copies are reproduced in Pl. XII. The stones in the northern wall of corridor (13) are designated N(orth) a(= course 1) and a number counting from the left or west. Those in the southern wall are designated *S a* for the first course, *S b* for the second course, and the numbers read from left (east) to right (west). See Appendix E.

When the granite casing wall was finished, as in rooms (7) and (8), and the roofing stones laid in place, the rooms must have been filled to the roof with the débris of the construction plane. This débris would have been removed from the top down and afforded a standing place for the workmen dressing the walls. I conclude that the granite casing was dressed from the top down as the construction was removed layer by layer at the convenience of the workmen, analogous to the practice in limestone building (see below). The pavement, doubtless of stone, was laid after the dressing of the walls, in the same way as the pavement and floors made for the brick-cased walls. In room (13), the crude-brick casing wall descended to the foundation platform and the floor had been formed by filling in the space between the crude-brick casing walls with about 60 cm. of limestone chips and covering this layer with mud plaster. This was true also of the entrance corridor and the great court, but in the great court a stone pavement had been laid on the mud.

Owing to the irregular floor in corridor (13), the height of the granite blocks of the first course varied considerably, but the height nowhere exceeded a meter. The top of the first course, however, was dressed to an even sloping line and the course line for the top of the second course was 87–88 cm. above the dressed top of the first course. In rooms (7) and (8), the emplacement marks on the walls indicated a much greater height for the courses of red granite casing in those two rooms, as is shown by the follow-

¹ See Borchardt, *Sa 'hure I*, pp. 92 and 96.

² See Sethe, *Urk. I*, p. 47.

³ See for both, Borchardt *Ne-user-re'*, p. 113.

⁴ See Murray, *Index of Names and Titles*, p. xxiv.

⁵ Maritte, *Mastabas*, p. 538; Lepsius, *Denkmäler*, II 34 e.

ing table. The last column gives course heights from the Chephren valley temple, of which those in brackets are from the hall of pillars:

Height of	Room (7)	Room (8)	Chephren
Course 1	158 cm.	183 cm.	172 cm.
Course 2	?113 cm.	130 cm.	154 cm.
Course 3	?112 cm.	120 cm.	111 cm.
Course 4	115 cm.	...	105 cm.
Course 5	?105 cm.	...	104 cm.
Height of architrave	?100 cm.	...	[100] cm.
From floor to bottom of architrave	367 cm.	...	[418] cm.
From rock to bottom of architrave (top of pillar)	510 cm.
From paved floor to ceiling	467 ± cm.	433 cm.	[518] cm.
From paved floor to top of core wall as preserved	421 cm.	514 cm.	...

The red granite casing blocks found complete measured:

- (1) Exposed face, 105 × 72 cm.; thickness, 88 cm. (Fig. 14.)
- (2) Exposed face, 107 × 73 cm.; thickness, 67 cm.

In order to correspond with the course heights, these must have been placed upright in the fourth or fifth course. Examples of blocks placed upright in the suggested position are S b 2 in corridor (13), the isolated block in the southern end of the portico, room (7), and the red granite blocks in the west wall of the hall of pillars in the Chephren valley temple.

In the portico a large fragment of a red granite lintel was found which I concluded had roofed the doorway between the portico and the offering room. On the underside was a rectangular socket for the upper socket block of the doorpost, and in the roof of the socket was a cylindrical hole, bored with a tube borer, to take the upper end of the doorpost. The height of the block was about 99 cm., — 84 cm. the height of the inside face plus 15 cm. the height of the ledge at the top of the door. Thus the top of the doorway was probably 99 cm. below the ceiling of the offering room (8), and therefore 334 cm. above the floor of that room. The lintel was 101 cm. thick, but as the other face had been split off, it may originally have been 110–130 cm. thick. The door jamb as reconstructed from the emplacement marks would have been about 90 cm. wide, a measure entirely compatible with the supposed thickness of the lintel. The length of the lintel, which would have fixed the width of the doorway, was quite indeterminate.

The marks on the floor of the western end of room (8), seen by Vyse and still visible, are the emplacements of three granite casing blocks, not the prints of pedestals. The middle stone is thicker than the other two and I reconstruct with a compound niche¹ to correspond with the thickness of the stones.

The square pillars and the antae in the portico were probably also of red granite on the analogy of the Chephren valley temple. The sockets in the floor indicated two rows:

- (1) Eastern row of four pillars and two antae.
- (2) Western row of two pillars and two antae.

The sockets in which they stood were sunk in the rock, which here forms the foundation of the temple, to a depth of 99–105 cm. (about two Egyptian ells) and were about 105 cm. square. The bottom of the sockets in the eastern row varied from 119 cm. to 136 cm. in depth below the floor of the portico, and the western sockets from 130 cm. to 148 cm. I calculate the height of the pillars from socket bottom to architrave at 456 cm. to 415 cm. according to the depth of the socket, or 367 cm. above the floor. I think there can be very little doubt that they were monolithic like the Chephren pillars.

The manner of the erection of these monoliths is indicated by the form of the sockets. The front or eastern side of the socket has been cut away to form a slope descending from the east, of the same width as the socket (100–105 cm.), but varying in length from 120 cm. to 150 cm. The slope descends below the level of the bottom of the socket so as to form a slight step (3–5 cm. high) just inside the eastern side of the socket. The process of erection I would reconstruct as follows (see Figs. 15, 16):

¹ See Fig. 10, p. 71.

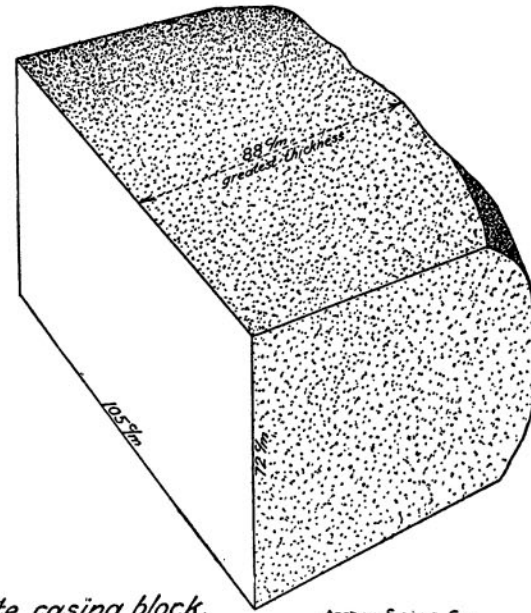

Red granite casing block.

APPROX. SCALE CM
0 10 20 30 40 50 60 70

FIGURE 14

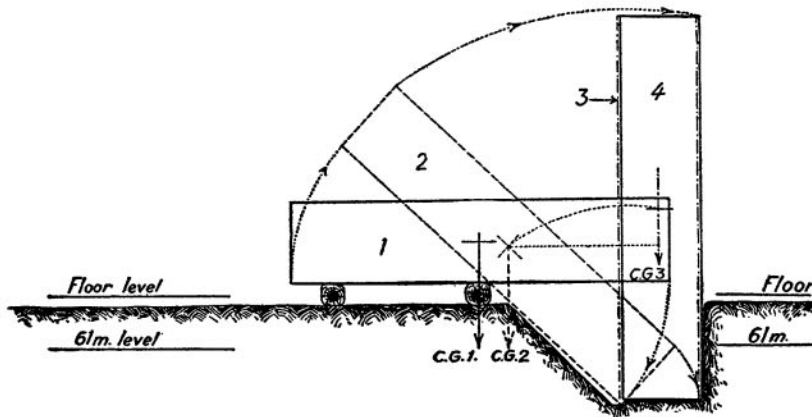

Proposed method of raising square pillars.

Scale 0 10 30 50 70 100 Cm.

FIGURE 15

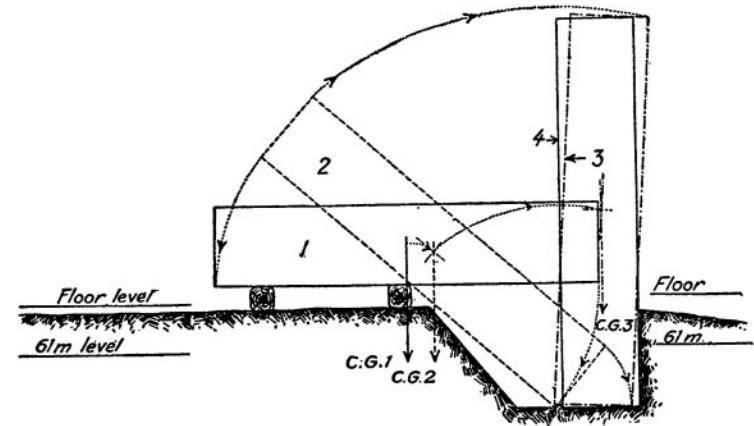

Proposed method of raising square pillars.

Scale 0 10 30 50 70 100 Cm.

FIGURE 16

- (1) The pillar, rough-dressed but not smooth, was dragged up on a sledge until it was beside the slope and the socket, with its butt approximately opposite the front third of the socket; being already 30–50 cm. above the floor, the pillar was then rolled over perhaps upon three wooden beams of height equal to that of the sledge; these beams were perpendicular to the side of the sledge; the pillar was then manoeuvred into place so that the butt end projected beyond the edge of the socket; the middle beam was not far from the center of gravity, perhaps a little west of it; the western beam was then worked out from under the stone, perhaps by breaking slightly the limestone under it, and the pillar left practically teetering on the middle beam; the weight to be lifted would have been small and by levering one end and pressing down on the other, the pillar would have been easily revolved on the middle beam as a fulcrum, until it rested on the slope with its lower edge against the step at the bottom of the slope.
- (2) The pillar at this stage made an angle of from 35° to 41° with the horizontal according to the slope of the socket in question; at any of these angles an effective pull could have been exerted with ropes held by men standing on the floor to the west or better on top of the massive walls; these stones weighed from 13–14 tons each but at that angle far less power was required to turn the stone on its lower edge than that required to lift the weight of the stone; the movement of the pillar would have been guided and restrained by ropes held by men standing in the court to the east; the rough surface of the pillar would have prevented the ropes from slipping, and the sides of the socket would also have assisted in guiding the pillar into place.
- (3) The sides of the socket have a thin layer of plaster, and it is probable that a thick layer of plaster was put in the bottom of the socket before setting the pillar to facilitate the final adjustment of the pillar by twisting it, if necessary, while standing; the plaster also served to fix the pillar in place; the slope was filled either with a single stone or with rubble and plaster.
- (4) The architrave and the roofing slabs were mounted from an inclined plane and construction platform; the architrave stones resting on the tops of the pillars were from 300 cm. to 370 cm. long measuring from the middle of one socket to the middle of another; the middle space in each row is wider (370 cm.); the width of the architrave was that of the pillars (ca. 100 cm.); and the height should have been the same on the analogy of the Chephren temple, but the marks on the wall indicate a height of 54 cm.
- (5) The final stage was the dressing of the pillars probably done at the same time as the dressing of the casing.

I infer that

- (a) In spite of the differences in height of the casing-courses in the two rooms, the casings of rooms (7) and (8) were built first and from the same construction planes.
- (b) The construction planes were then removed, at least as far as the doorway to room (8), and the pillars erected.
- (c) The construction planes were then rebuilt for the architraves and roof of the portico.
- (d) The casings and the pillars were dressed by workmen standing on the construction platform, which was removed as the smoothing of the walls and the pillars progressed, working downwards.

But it is possible that room (8) was finished before the portico was begun, in which case the planes would have been twice removed before the final clearance.

The roofing of the portico and the offering room is to be reconstructed on the analogy of the valley temple of Chephren. In the portico the square red granite architraves ran north and south over the tops of the pillars and the antae; and on these the roofing slabs were laid running east and west. The front edge of the portico roof was probably quite plain and square cut.¹

The dressing of the granite at the Mycerinus pyramid and temples, wherever it was found and in whatever state of completion, showed traces of only three processes — hammering, rubbing, and boring with a cylindrical borer. The cylindrical or tubular borer was used, as far as our evidence goes, only for boring sockets to take the ends of doorposts and the ends of bolts, and consequently was not of general utility in construction.² The hammering and the rubbing processes were however everywhere in evidence, especially in the casing of the Third Pyramid where large ridges had been worked out by pounding and rubbing, and these ridges were often partly broken off by smashing blows with the point of impact on the upper side of the ridge. Three types of stone implement were found in and about the temples:

- (1) A large two-handed hammer or rubber.
- (2) A large hammer which was used with a wooden handle.
- (3) Rough hammers and rubbers held in the hand, or in both hands.

¹ Cf. Professor Borchardt's reconstructions of the temple of Sahura.

² See Chapters VII and VIII.